

# EUROMACH



Management System  
ISO 9001:2015



www.tuv.com  
ID 9109027671

# New R855 Big Foot / Forester



# EUROMACH

Creata nel 1977, la Euromach Srl garantisce ai clienti (50% dei quali all'estero) 50 anni di esperienza nella costruzione di escavatori ragno (oltre 4000 in tutto il mondo) destinati non solamente alle aree montane, ma anche a quelle paludose, ai canali e nei boschi. L'azienda è certificata ISO 9001 e collabora con i principali produttori mondiali di componenti tecnologici per il miglioramento costante e la ricerca continua di nuove soluzioni per accrescere l'efficienza e la sicurezza delle macchine, alla base del successo dell'azienda. Gli escavatori "ragno" Euromach si distinguono per la loro capacità di lavorare in terreni molto ripidi e difficili, dove l'accesso ai normali mezzi è proibito.

Set up in 1977, Euromach S.r.l grants to their customer (50% of which in foreign countries) 50 years of experience in the construction of walking excavators (more than 4000 all around the world), that are destined to work not only in mountain areas, but also in swamps, channels and in the woods. The company obtained also the certification ISO 9001 and cooperates with the main world producers of technological components for constant improvement and machines' security, which are the reasons behind the company success. Euromach excavators are ideally suited to work on very steep or rough-terrain sites, where access is severely restricted.

Crée en 1977, Euromach Srl garantie aux clients (dont 50% à l'étranger) 50 années d'expérience dans la construction des pelles araignées (plus de 4000 dans le monde entier) aux terrains de montagne, mais aussi terrains maraîchagers, aux cours d'eau et dans les bois. L'entreprise est certifiée ISO 9001 et collabore avec les principaux producteurs mondiales de composants technologiques pour une amélioration constante et une recherche continue des nouvelles solutions dans le but d'augmenter l'efficacité et la sécurité des machines, qui sont à la base du succès de l'entreprise. Les pelles araignées Euromach se distinguent pour leur capacité à travailler dans des terrains très raides et difficiles, ou l'accès aux moyens traditionnels est interdit.

Die Firma Euromach Srl, wurde im Jahr 1977 gegründet und bringt somit ihren Kunden, welche sich zu 50% im Ausland (mehr als 4000 in der Welt) befindet, eine Erfahrung von über 50 Jahren in der Herstellung von Schreitbaggern entgegen und bürgt daher für technologisch innovative Produkte. Diese Schreitbagger sind für Einsätze konstruiert, welche für andere Maschinen nicht oder nur schwer durchführbar sind. Diese Einsätze beschränken sich nicht nur auf Bergland, Euromach Schreitbagger eignen sich auch besonders gut für Einsätze in sumpfigen Gebieten, Kanälen und im Wald. Die ISO 9001 Zertifikat gewährleistet die Verwendung von technologischen Komponenten marktführender namhafter Hersteller und eine stetige Forschung und Weiterentwicklung um die Leistung, Standhaftigkeit und Sicherheit der Maschinen zu erhöhen, was nicht zuletzt den Erfolg der Firma begründet.



TIGROTTO



1300 SUPER JOLLY



3500 MOBILE



5500 MOBILE



6500 MOBILE



R105

## New R855 Big Foot / Forester



Il nuovo escavatore Euromach R855 monta un motore DEUTZ da 142 HP omologato Stage V con filtro antiparticolato e AD BLUE; una nuova cabina con migliore visibilità, ergonomia, design e nuovi cofani che ne migliorano l'estetica. L'impianto idraulico per la traslazione ha una pompa idrostatica Rexroth e il distributore del braccio è di tipo Load Sensing. L'impianto idraulico è composto da n. 4 pompe. Per i paesi dove non è richiesto è possibile montare motori senza fap ed adblue.

The new Euromach R855 excavator is equipped with a 142 HP Stage V approved DEUTZ engine with particulate filter and AD BLUE; a new cab with improved visibility, ergonomics, design and new hoods that improve its aesthetics. The hydraulic system for the translation has a Rexroth hydrostatic pump and the boom distributor is of the Load Sensing type. The plumbing system consists of n. 4 pumps. For countries where it is not required it is possible to mount motors without DPF and AdBlue.

La nouvelle pelle Euromach R855 est équipée d'un moteur DEUTZ de 142 CV homologué Stage V avec filtre à particules et AD BLUE; une nouvelle cabine avec une visibilité, une ergonomie, un design améliorés et de nouveaux capots qui améliorent son esthétique. Le système hydraulique de translation est équipé d'une pompe hydrostatique Rexroth et le répartiteur de flèche est du type Load Sensing. Le système de plomberie se compose de n. 4 pompes. Pour les pays où elle n'est pas requise il est possible de monter des moteurs sans FAP ni AdBlue.

Der neue Bagger Euromach R855 ist mit einem von der Stufe V zugelassenen DEUTZ-Motor mit 142 PS, Partikelfilter und AD BLUE ausgestattet. Eine neue Kabine mit verbesserter Ergonomie, Design und neuen Motorhauben, die die Ästhetik verbessern. Das Hydrauliksystem für die Übersetzung verfügt über eine hydrostatische Rexroth-Pumpe und der Auslegerverteiler ist vom Typ Load Sensing. Das Sanitärssystem besteht aus n. 4 Pumpen. Für Länder, in denen dies nicht erforderlich ist Es ist möglich, Motoren ohne DPF und AdBlue zu montieren.

## Escavatori Euromach / Euromach excavators Pelles Euromach / Bagger Euromach

1500 MOBILE



R25



R455



R 555-H



R 755-H



R855 BIGFOOT



R955



R1055



R1255



R145







# EUROMAGH













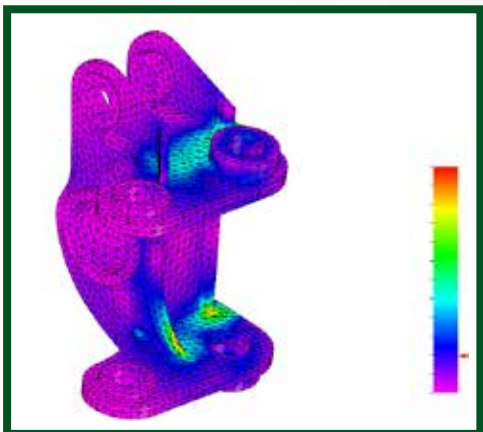
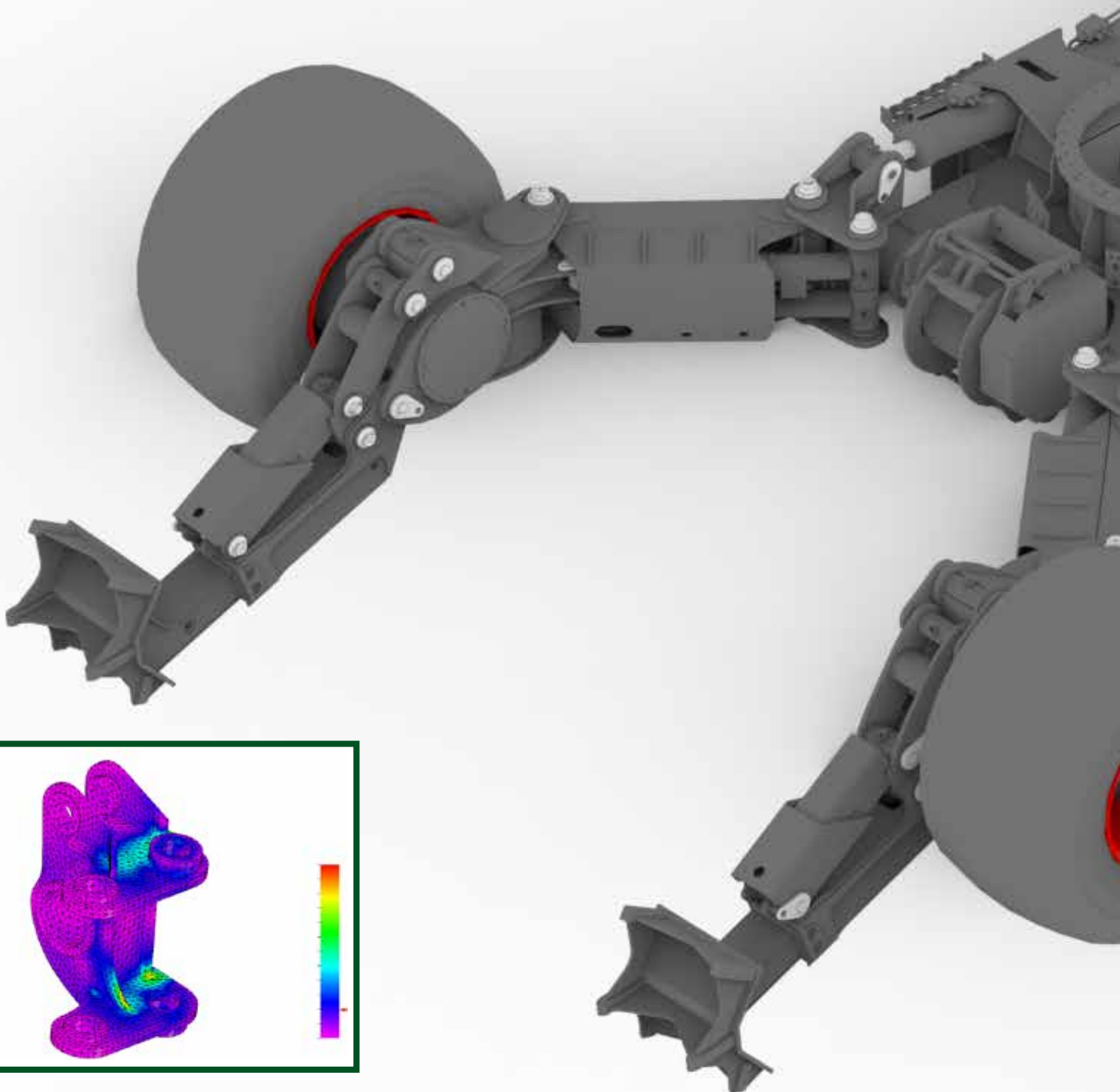
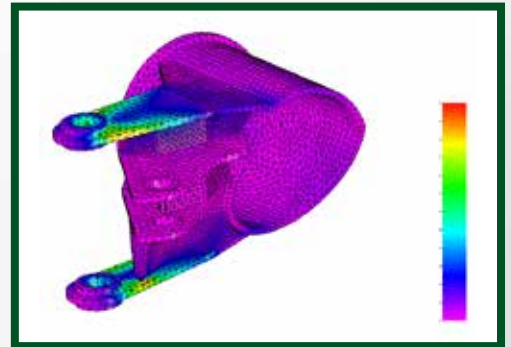

# Châssis / Chassis

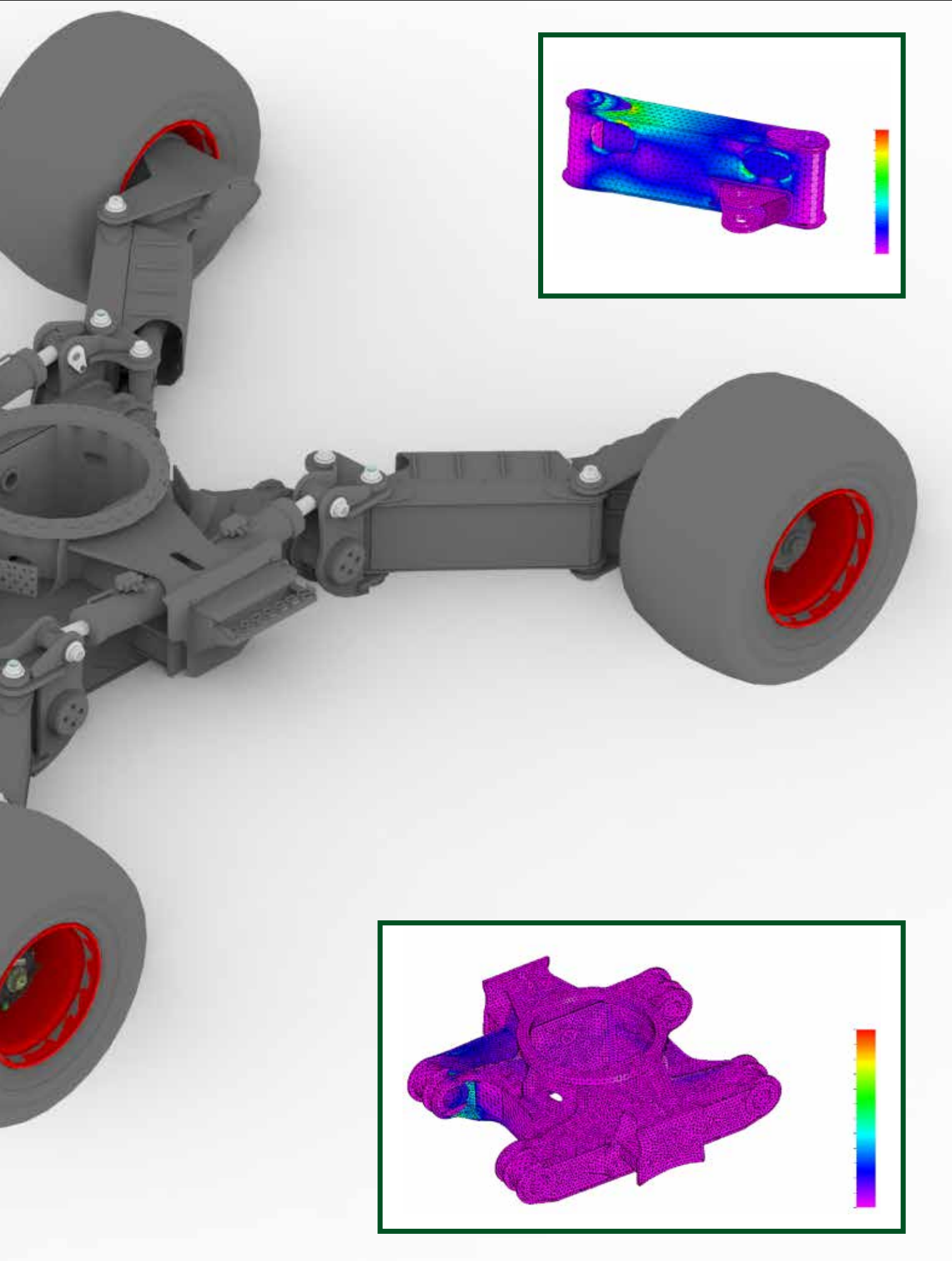



# Braccio / Boom / Bras / Arm



**2 configurazioni di braccio possibili con sfilo da 1400 e 1500 mm.**

**2 arm configurations possible with boom extension of 1400 and 1500 mm.**

**2 configurations de bras possibles avec télescope de 1400 et 1500 mm.**

**2 Armkonfigurationen mit 1400 und 1500 mm Teleskop möglich.**



**N. 5 tubi di serie in punta al braccio. In opzione personalizzabile fino a n. 13 tubi.**

**N. 5 standard tubes at the end of the boom. In option customizable until to n. 13 tubes.**

**Num. 5 tuyaux de série à la fin du bras. En option personnalisable jusqu'à n. 13 tuyaux.**

**Nr. 5 serienmäßige Ölleitungen am Ende des Armes. Optional anpassbar bis zu n. 13 Ölleitungen.**



**Valvole di sicurezza su bracci.**

**Security valves on the booms.**

**Clapets de sécurité sur les bras.**

**Ventilenkit über die Zylindern.**



**Tutti i tubi a sinistra in posizione visibile.**

**All the pipes on the left in visible position.**

**Touts les tuyaux à la gauche en position visible.**

**Alle Leitungen an der linken Seite in einer gut sichtbaren Position.**



**Bielle e puntone rinforzati.**

**Balance rod and strut rod REINFORCED.**

**Bielletes et puntone RENFORCÉ.**

**Pleuel und Löffelstange VERSTÄRKT.**





# Telaio / Chassis / Châssis / Chassis





# Nuovi accessori / New accessories / N

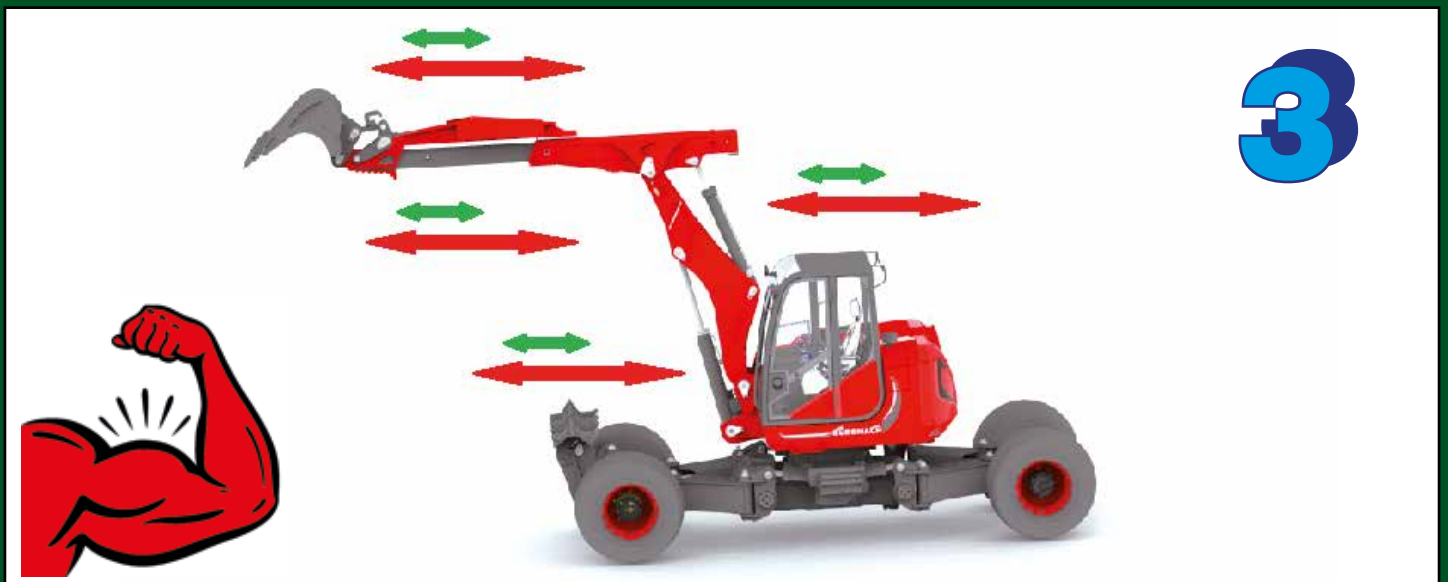
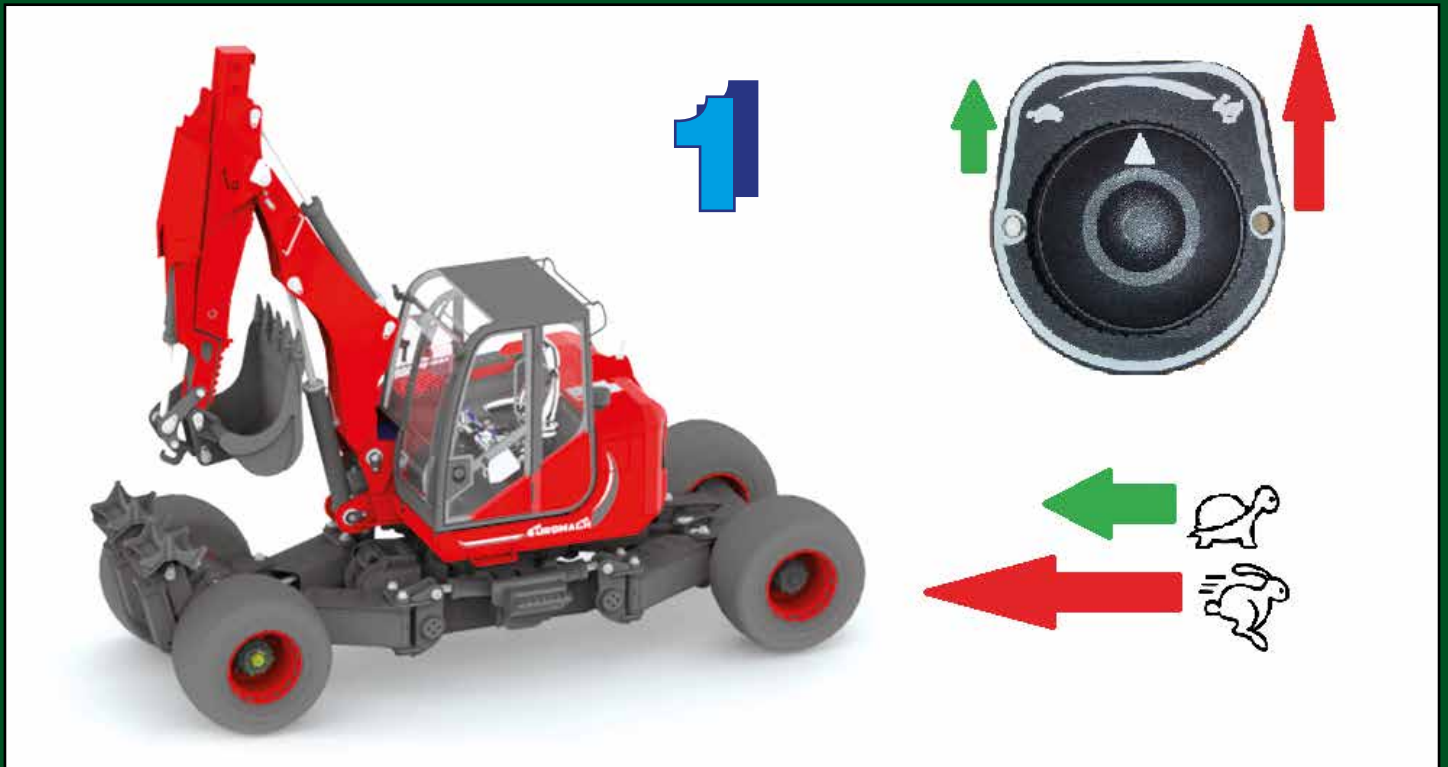



# Nouveaux accessoires / Neue Zubehöre

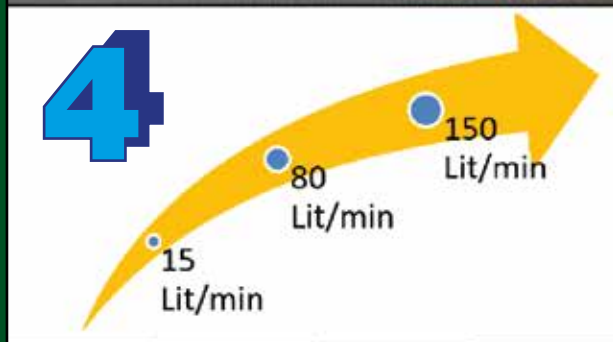
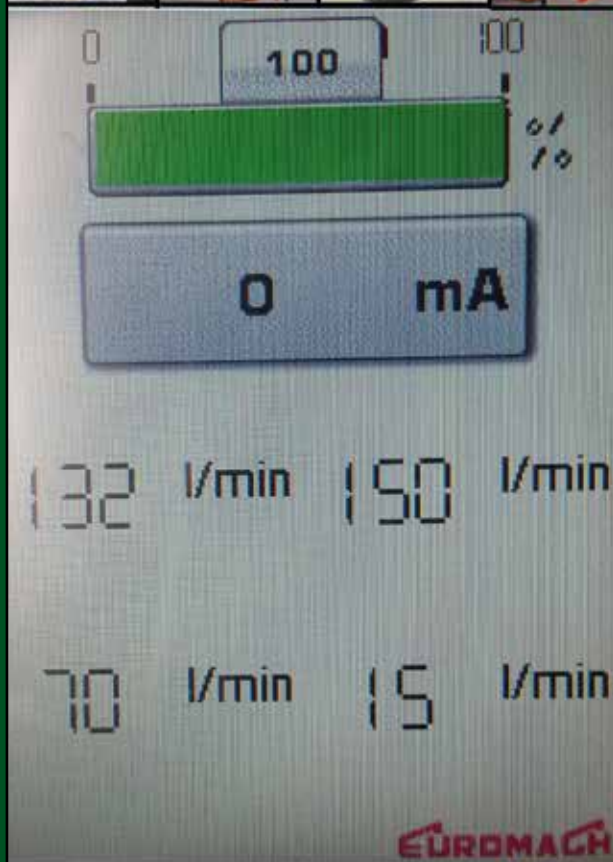

5









# Motore / Engine / Moteur / Motor

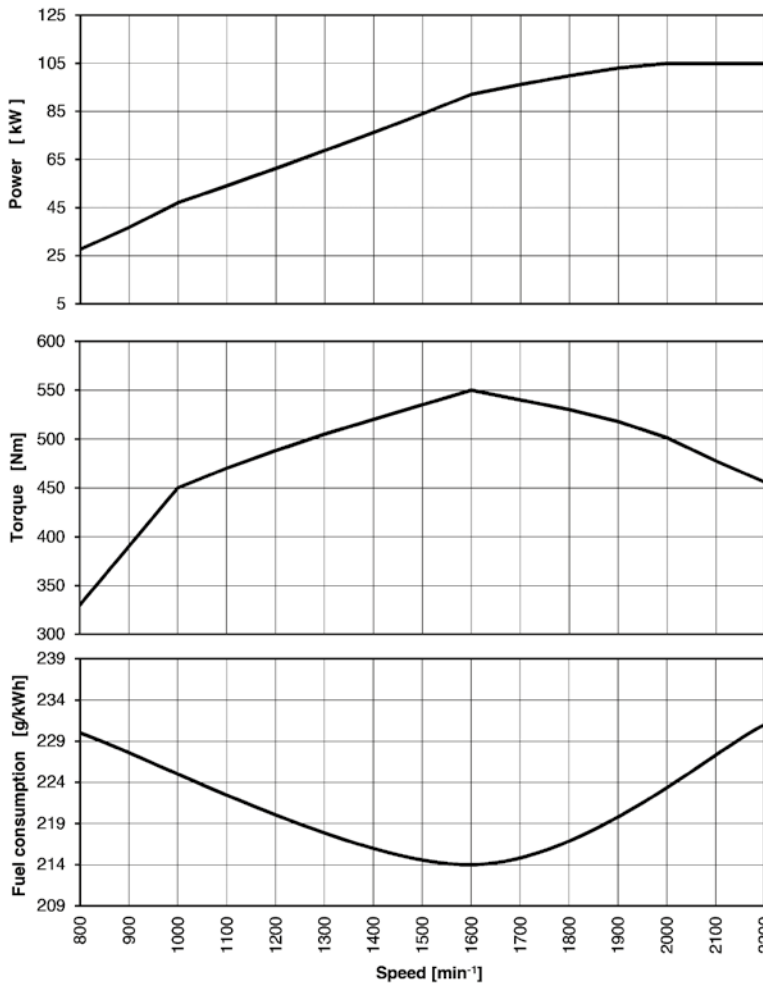

**Modello:** DEUTZ V3600 Stage V con filtro antiparticolato e AD BLUE  
**Tipo:** Diesel Turbo 4 tempi raffreddato ad acqua, Intercooler  
**Numero cilindri:** 4  
**Cilindrata:** 3600  $\text{cm}^3$   
**Potenza massima:** 142 Hp (105 kW)  
**Tensione alimentazione:** 24 V  
**Alternatore:** 55 A/h

**Model:** DEUTZ V3600 Stage V with particulate filter and AD BLUE  
**Type:** Water-cooled 4-stroke Turbo Diesel, Intercooler  
**Number of cylinders:** 4  
**Displacement:** 3600  $\text{cm}^3$   
**Maximum power:** 142 Hp (105 kW)  
**Power supply voltage:** 24 V  
**Alternator:** 55 A/h

**Modèle:** DEUTZ V3600 Stage V avec filtre à particules et AD BLUE  
**Type:** Turbo Diesel 4 temps refroidi par eau, refroidisseur intermédiaire  
**Nombre de cylindres:** 4  
**Déplacement:** 3600  $\text{cm}^3$   
**Puissance maximale:** 142 Hp (105 kW)  
**Tension d'alimentation:** 24 V  
**Alternateur:** 55 A/h

**Modell:** DEUTZ V3600 Stufe V mit Partikelfilter und AD BLUE  
**Typ:** Wassergekühlter 4-Takt-Turbodiesel, Ladeluftkühler  
**Anzahl der Zylinder:** 4  
**Verschiebung:** 3600  $\text{cm}^3$   
**Maximale Leistung:** 142 PS (105 kW)  
**Versorgungsspannung:** 24 V  
**Lichtmaschine:** 55 A/h

## STAGE V





# Nuove sensibilità e affidabilità New sensibility and reliability

**Valvola Rexroth di nuova concezione sul cilindro di sollevamento (più sensibile).**

**Nuova valvola Rexroth rigenerativa sul cilindro del secondo braccio.**

**Rexroth valve of new concept on the lifting boom (more sensibility).**

**New regenerative Rexroth valve on the second boom cylinder.**

**Valve Rexroth de nouvelle conception sur le vérin du levage (plus sensible).**

**Nouvelle valve régénératrice Rexroth sur le vérin du deuxième bras.**

**Rexroth Ventil von neuer Konzeption auf dem Hubzylinder (mehr Sensibilität).**

**Neues regeneratives Rexroth Ventil auf dem Zylinder des zweites Armes.**



 **POCLAIN**<sup>®</sup>  
Hydraulics

**Rex**  
Bosch





# Nouvelle sensibilité et fiabilité Neue Sensibilität und Zuverlässigkeit



Una nuova valvola Rexroth sul traino funge da blocco del differenziale. Le 4 ruote si muoveranno in modo sincrono anche con differenti pressioni al suolo delle stesse.

A new Rexroth valve on the traction makes the differential locking device function. The 4 wheels will move synchronously even if they have different pressures to the ground.

Une nouvelle valve Rexroth sur la traction fait le blocage du différentiel. Les 4 roues se déplacent en manière synchrone même s'elles ont des pressions différentes sur le sol.

Ein neues Ventil Rexroth auf den Antrieb macht die FunktionsSperrdifferential. 4 Räder werden in einer synchronen Weise, sogar mit unterschiedlichen Drücken auf den Boden bewegt.

**roth**®  
Group

## Option



Abbiamo sviluppato dei nuovi corpi manipolatori. Lo sforzo per comandare la leva è molto basso e la sensibilità sul movimento del cilindro molto maggiore. In opzione si possono montare i manipolatori Girmatic a 33+33 funzioni singole.

We have developed new bodies for the manipulators. The effort to control the lever is very low and the sensitivity on the cylinder movement is higher. Optionally they can be mounted Girmatic manipulators with 33+33 single functions.

Nous avons développé de nouveaux corps de manipulateurs. L'effort pour contrôler le levier est très bas et la sensibilité sur le mouvement du vérin est supérieure. En option, ils peuvent être montés Manipulateurs Girmatic avec 33+33 fonctions simples.

Wir haben neue Körper für die Manipulatoren entwickelt. Der Aufwand um den Hebel zu kontrollieren ist sehr niedrig und die Sensibilität der Zylinderbewegung ist viel größer. Optional können sie montiert werden Girmatic Manipulatoren mit 33+33 Einzelfunktionen.

**walvoil**  
FLUID POWER E MOTION

**GIRMATIC**



# Impianto principale - Braccio

## Main system - Boom

### Système principal - Bras

#### Hauptanlage - Arm



**Rexroth**<sup>®</sup>  
Bosch Group



**N. 4 pompe**

**Distributore LOAD SENSING**

**Totale olio: 180 + 180 + 130 + 30 = 520 l/min**

**Pressione di lavoro: 300 bar**

**Pressione di lavoro sui bracci: 300 bar**

**Pressione di lavoro sul traino: 450 bar**

**N. 4 pumps**

**Valve LOAD SENSING**

**Total oil: 180 + 180 + 130 + 30 = 520 l/min**

**Working pressure: 300 bar**

**Working pressure on the arms: 300 bar**

**Working pressure on towing: 450 bar**

**N. 4 pompes**

**Distributeur LOAD SENSING**

**Totale huile: 180 + 180 + 130 + 30 = 520 l/min**

**Pression de travail: 300 bar**

**Pression de travail sur les bras: 300 bar**

**Pression de travail sur la traction: 450 bar**

**N. 4 Pumpen**

**Verteiler LOAD SENSING**

**Gesamtöl: 180 + 180 + 130 + 30 = 520 l/min**

**Arbeitsdruck: 300 bar**

**Arbeitsdruck auf die Arme: 300 bar**

**Arbeitsdruck beim Abschleppen: 450 bar**



**Impianto di traslazione mediante doppia pompa idrostatica  
Rexroth e motori idraulici Rexroth a cilindrata variabile**

**Translation system by Rexroth double hydrostatic pump  
and Rexroth variable displacement hydraulic motors**

**Système de translation au moyen d'une double pompe  
hydrostatique Rexroth et moteurs hydrauliques  
à cylindrée variable Rexroth**

**Translationssystem mittels Rexroth doppel-hydrostatikpumpe  
und Rexroth-hydraulikmotoren mit variablem hubraum**

**Impianto di traslazione mediante pompa idrostatica e motori Rexroth a cilindrata variabile.**

**Pressione di lavoro 450 bar  
Portata massima 130 L/min  
Velocità massima 8 Km/h  
Grande potenza.**

**Translation system with hydrostatic Rexroth pump and variable displacement engines.**

**Working pressure 450 bar  
Max. displacement 130 L/min  
Max. speed 8 Km/h  
Big power.**

**Système de translation avec pompe hydrostatique et moteurs Rexroth à débit variable.**

**Pression de travail 450 bar  
Débit maximum 130 L/min  
Vitesse maximum 8 Km/h  
Grande puissance.**

**Fahrertriebspumpe vom Typ „Rexroth“ hydrostatisch und Motor mit variabler Leistung.  
Arbeitsdruck 450 bar  
Max. Leistung 130 L/min  
Höchstgeschwindigkeit 8 Km/h  
Große Macht.**



**Rexroth**  
Bosch Group





Option

# SPL

**Pompa dedicata SPL** per accessorio con portata e pressione settabili da computer

Pmax=150 lit/min

**SPL dedicated pump** for hydraulic accessory with flow rate and pressure adjustable by computer

Pmax=150 lit/min

**Pompe SPL dédiée** pour accessoire hydraulique avec débit et pression réglables par ordinateur

Pmax=150 lit/min

**Spezielle SPL-Pumpe** für hydraulische Anbaugeräte mit computergesteuerter Durchflussmenge und Druck

Pmax=150 lit/min

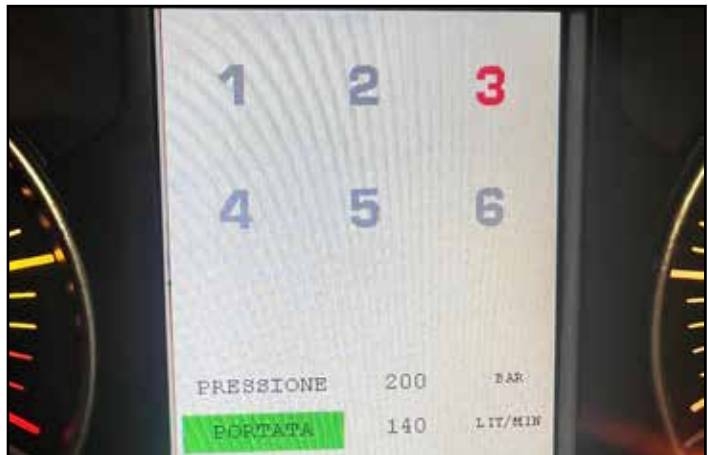

Option

# PL

**Linea prioritaria** per accessorio idraulico con portata e pressione settabili da computer.

Pmax=120 lit/min

**Priority line** for hydraulic attachment with flow rate and pressure settable from computer.

Pmax=120 lit/min

**Ligne prioritaire** pour l'accessoire hydraulique avec débit et pression réglables à partir d'un ordinateur.

Pmax=120 lit/min

**Prioritätsleitung** für hydraulische Anbaugeräte mit Durchflussmenge und Druck vom Computer einstellbar.

Pmax=120 lit/min

# Cabina / Cab / Cabine / Kabine





# New R855 Big Foot / Forester

## DATI PRINCIPALI

- ⇒ N° 2 serbatoi del gasolio = 270 lit (principale 110 lit, secondario nel telaio 160 lit). L'escavatore è munito di una pompa per il trasferimento del carburante dal serbatoio secondario a quello principale (travasamento elettrico optional).
- ⇒ Cabina antiribaltamento, nuovo disegno, con vetro apribile verso l'interno, ROPS/FOPS, miglior comfort e più spazio per l'operatore; cristalli temperati, autoradio con CD e sedile ad aria.
- ⇒ I componenti maggiormente sollecitati sono realizzati utilizzando materiali ad alto limite elastico. I cucchiai ed i piedi di appoggio sono con particolari acciai antiusura per aumentarne la resistenza all'uso. I perni sono realizzati in acciaio 16CrNi4 cementato e gli steli dei cilindri sono in 42CrMo4 bonificato e temprato ad induzione e successivamente cromato per avere massima robustezza e resistenza all'usura.

## MAIN DATA

- ⇒ N° 2 diesel tanks = 270 lit (main tank 110 lit, secondary tank 160 lit). The excavator is equipped with a pump that can be used to transfer the Diesel from the secondary tank to the main tank (optional electric pouring).
- ⇒ Anti-roll cabin, new design, front window opens towards the cabin, ROPS/FOPS, more comfort, more space for the operator, tempered and colored glass windows, car radio set with CDs, air seat.
- ⇒ The most stressed parts of the excavator are made out of high strength steel. Buckets and legs are made out of special steel that has a high resistance against wearing. The pins are made out of case-hardened 16CrNi4 steel and the cylinders piston rods are made out off induction hardened and tempered 42CrMo4 steel successively chromed to warrant a good strength and a surface resistance against chocks.

## DONNES PRINCIPALES

- ⇒ N° 2 réservoirs à gasoil = 270 lit (principale 110 lit, réserve 160 lit). La pelle est équipée d'une pompe qui peut être utilisé pour le transfert du carburant du réservoir secondaire à ce principal (transfert automatique du gasoil en option).
- ⇒ Cabine anti-renversement, nouvel design, vitre antérieure avec ouverture à l'intérieur, ROPS/FOPS, plus de confort, plus d'espace pour l'opérateur, glaces trempées et colorées, autoradio avec CD, siège à air.
- ⇒ Les parties de l'excavateur les plus fatiguées, sont réalisées avec de matériels qui ont une limite d'élasticité très élevée. Les bennes et les pieds d'appui sont réalisés en acier spécial avec une résistance élevée à l'usure. Les pivots sont réalisés en acier 16CrNi4 cimenté et les tiges des cylindres sont réalisés en acier 42CrMo4 bonifié et trempé à induction et successivement chromé afin de garantir une considérable robustesse et une résistance de la surfaces aux chocs très élevés.

## HAUPTDATEN

- ⇒ N° 2 Treibstofftanks = 270 Lit. (Haupttank 110 Lit, Ersatztank 160 Lit). Eine spezifische Tankpumpe wird geliefert, um den Treibstoff vom Ersatztank in den Haupttank zu pumpen (elektrisches Umfüllen in Option).
- ⇒ Kippsichere Kabine, neues Design, Vorderscheibe mit Öffnung nach Innen, ROPS/FOPS, besseren Komfort, mehr Platzangebot für der Maschinenführer, gehärtete Scheiben, Autoradio mit CD, LuftsitzKab.
- ⇒ Die Komponente des Baggers, welche Höchstbeanspruchung haben, werden aus hohem elastischem Qualitätsmaterial hergestellt. Die Löffeln und die Auf lagefüße werden aus besonderen Antiverschleißstählen gemacht, um die Gebrauchsfestigkeit zu erhöhen. Die Bolzen werden aus Stahl 16CrNi4 hergestellt und die Kolbenstangen werden aus vergütetem, induktionsgehärtetem und danach verchromten 42CrMo4 Stahl hergestellt; das verbürgt für eine bemerkenswerte Stärke und eine hohe oberflächliche Schlagfestigkeit.

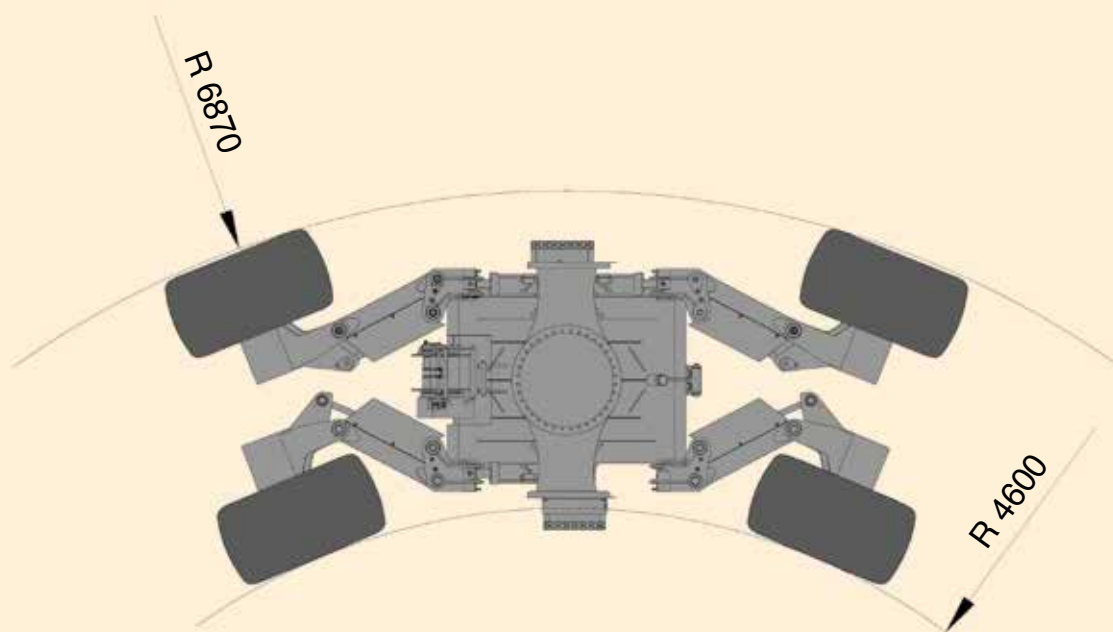

# Forester version

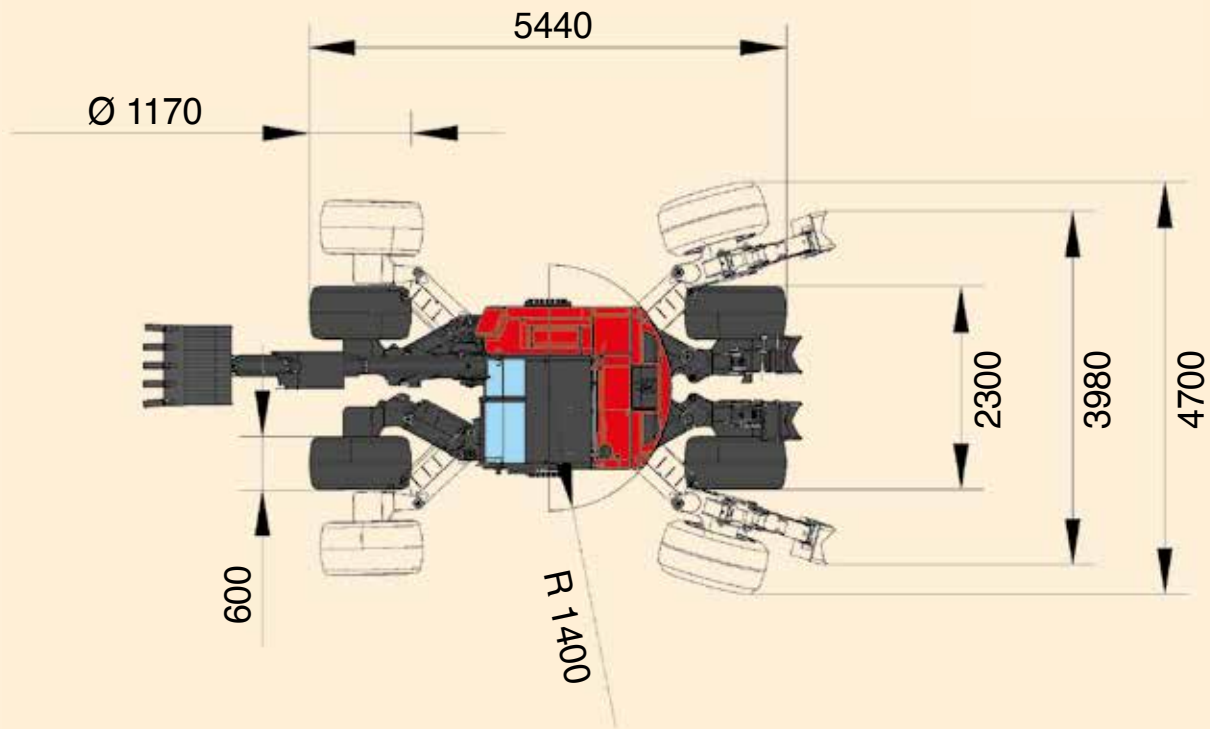



# New R855 Big Foot / Forester









# New R855 Big Foot 1400 mm

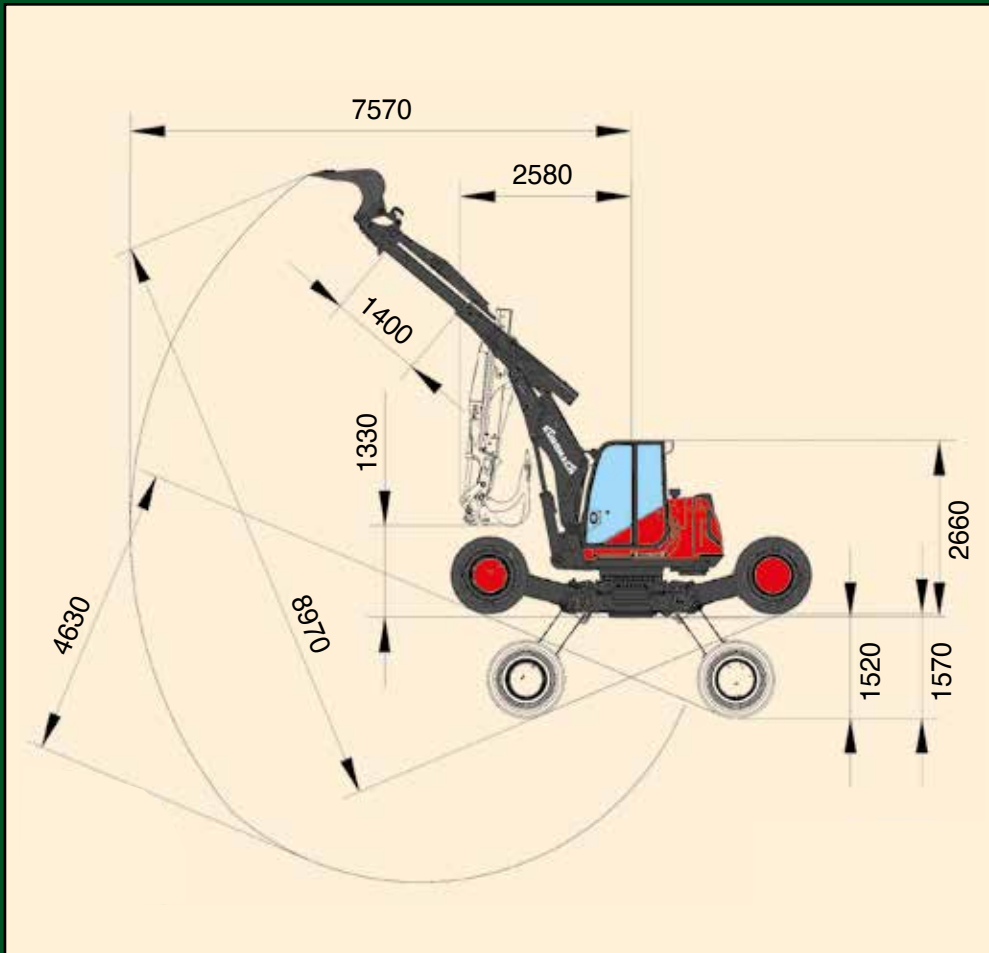

**Peso:** da 10900 kg  
**Sfilo braccio:** 1,4 m  
**Sbraccio massimo:** 7,57 m  
**Forza di strappo:** 85 kn  
**Forza di penetrazione:** 69 kn

**Weight:** from 10900 kg  
**Boom extension:** 1,4 m  
**Max. boom length:** 7,57 m  
**Brake off force:** 85 kn  
**Penetration force:** 69 kn

**Poids:** de 10900 kg  
**Extension du bras:** 1,4 m  
**Longueur max. bras:** 7,57 m  
**Force d'enlèvement:** 85 kn  
**Force de pénétration:** 69 kn

**Gewicht:** von 10900 kg  
**Teleskop Ausleger:** 1,4 m  
**Höchstrechtweite:** 7,57 m  
**Reißkraft:** 85 kn  
**Durchschlagskraft:** 69 kn

# New R855 Big Foot 1500 mm

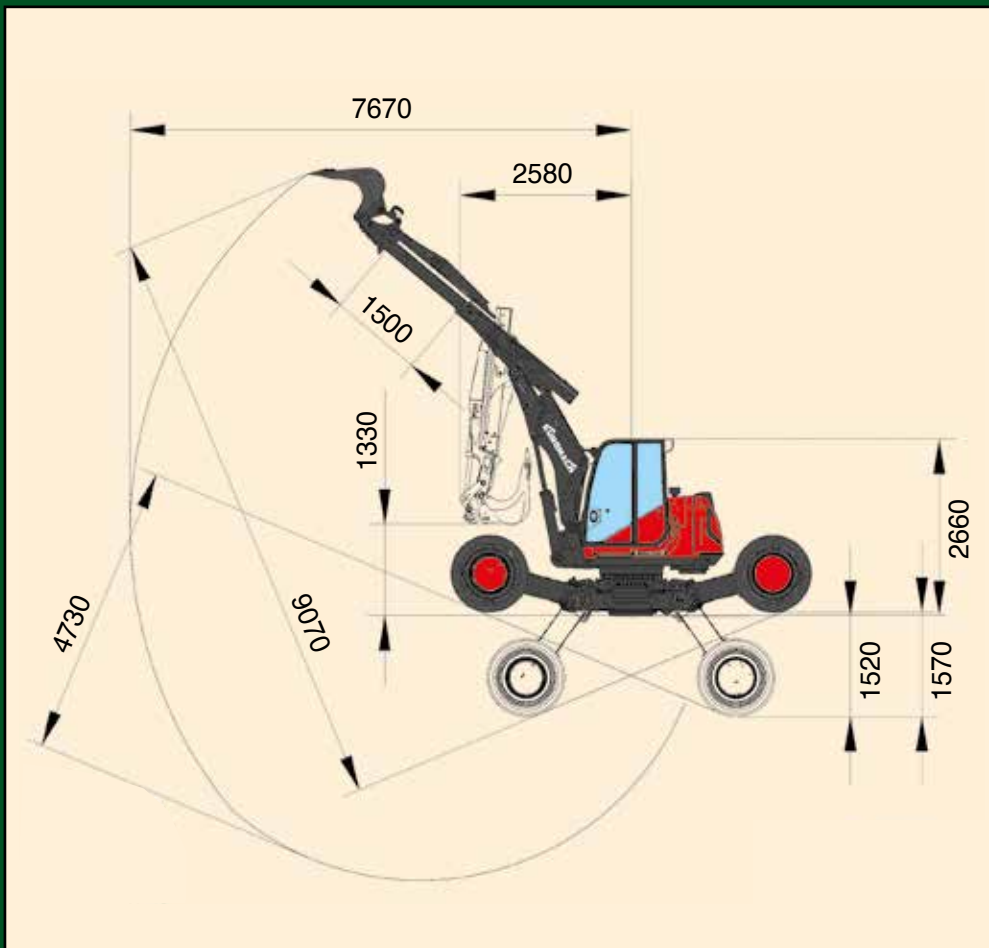

**Peso:** da 11000 kg  
**Sfilo braccio:** 1,5 m  
**Sbraccio massimo:** 7,67 m  
**Forza di strappo:** 85 kn  
**Forza di penetrazione:** 69 kn

**Weight:** from 11000 kg  
**Boom extension:** 1,5 m  
**Max. boom length:** 7,67 m  
**Brake off force:** 85 kn  
**Penetration force:** 69 kn

**Poids:** de 11000 kg  
**Extension du bras:** 1,5 m  
**Longueur max. bras:** 7,67 m  
**Force d'enlèvement:** 85 kn  
**Force de pénétration:** 69 kn

**Gewicht:** von 11000 kg  
**Teleskop Ausleger:** 1,5 m  
**Höchstrechtweite:** 7,67 m  
**Reißkraft:** 85 kn  
**Durchschlagskraft:** 69 kn

# New R855 Forester 1400 mm

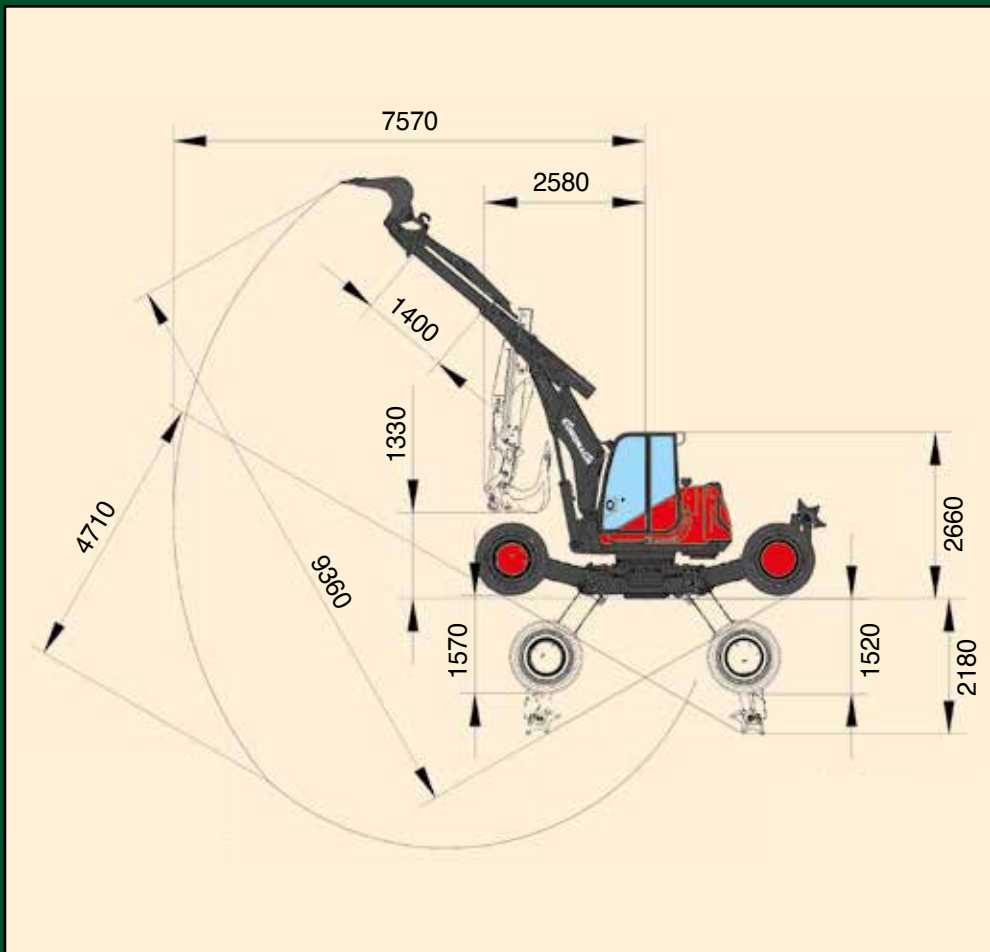

**Peso:** da 11400 kg  
**Sfilo braccio:** 1,4 m  
**Sbraccio massimo:** 7,57 m  
**Forza di strappo:** 85 kn  
**Forza di penetrazione:** 69 kn

**Weight:** from 11400 kg  
**Boom extension:** 1,4 m  
**Max. boom length:** 7,57 m  
**Brake off force:** 85 kn  
**Penetration force:** 69 kn

**Poids:** de 11400 kg  
**Extension du bras:** 1,4 m  
**Longueur max. bras:** 7,57 m  
**Force d'enlèvement:** 85 kn  
**Force de pénétration:** 69 kn

**Gewicht:** von 11400 kg  
**Teleskop Ausleger:** 1,4 m  
**Höchstrechtweite:** 7,57 m  
**Reißkraft:** 85 kn  
**Durchschlagskraft:** 69 kn

# New R855 Forester 1500 mm

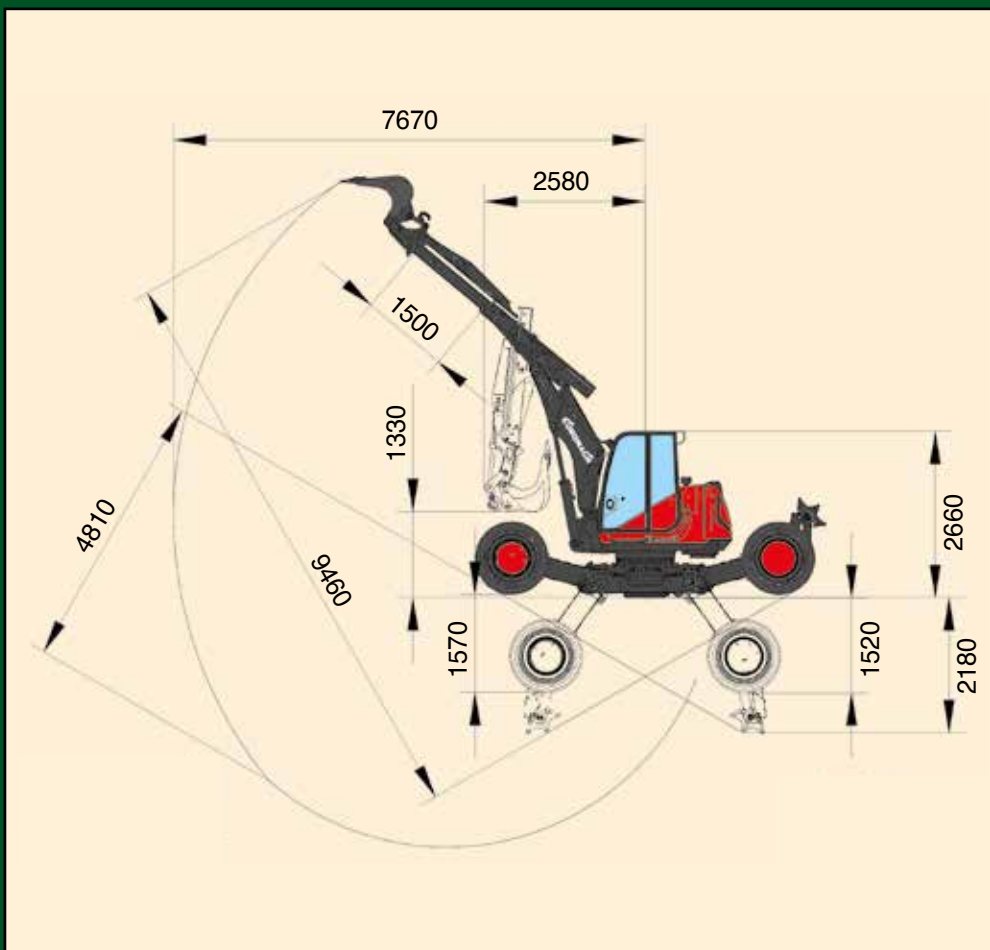

**Peso:** da 11500 kg  
**Sfilo braccio:** 1,5 m  
**Sbraccio massimo:** 7,67 m  
**Forza di strappo:** 85 kn  
**Forza di penetrazione:** 69 kn

**Weight:** from 11500 kg  
**Boom extension:** 1,5 m  
**Max. boom length:** 7,67 m  
**Brake off force:** 85 kn  
**Penetration force:** 69 kn

**Poids:** de 11500 kg  
**Extension du bras:** 1,5 m  
**Longueur max. bras:** 7,67 m  
**Force d'enlèvement:** 85 kn  
**Force de pénétration:** 69 kn

**Gewicht:** von 11500 kg  
**Teleskop Ausleger:** 1,5 m  
**Höchstrechtweite:** 7,67 m  
**Reißkraft:** 85 kn  
**Durchschlagskraft:** 69 kn



# Accessori / Accessories

## CUCCHIAI / BUCKETS / BENNES / LÖFFELN



## ARGANI / WINCHES / TREUILS / WINDEN



## PINZE / GRABS / BENNES PRENEUSES / GREIFERN





# / Accessoires / Zubehöre

## FRESE E PROCESSORI / MULCHERS AND PROCESSORS BROYEURS ET PROCESSEURS / MULCHERN UND PROZESSOREN



## ROTATORI E ATTACCHI RAPIDI / ROTATORS AND QUICK COUPLERS ROTATEURS ET ATTACHES RAPIDES / ROTATOREN UND SCHNELLWECHSLERN



## ALTRI ACCESSORI / OTHER ATTACHMENTS AUTRES EQUIPEMENTS / ANDERE ZUBEHÖRE







## New R855 Big Foot / Forester

EUROMACH S.R.L.  
25018 MONTICHIARI (Brescia)  
ITALY  
Via Gabriele D'Annunzio, 28/30  
Phone 0039(0)-30-9960527  
Fax 0039(0)-30-9960363  
www.euromach.com  
e-mail: euromach@euromach.com



- A fronte di una continua ricerca tecnologica, i dati possono cambiare senza preavviso. Contattare il nostro Ufficio Commerciale per ulteriori informazioni.  
- Because of continuous technology research data can change without notice. Please, contact our Commercial Dept. for further information.  
- Vu la recherche technologique continue, les données peuvent changer sans préavis. Contacter notre Bureau Commercial pour des autres informations.  
- Wegen technischer Forschung, können die Daten fristlos ändern. Unser Vertrieb erteilt Ihnen gerne weitere Auskünfte, bitte rufen Sie an.

Ed 2025 - Rev 1