

# EUROMACH

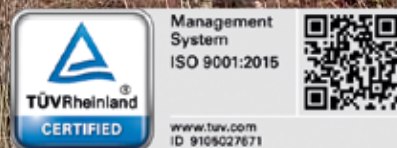

# R955 super

# EUROMACH

Creata nel 1977, la Euromach Srl garantisce ai clienti (50% dei quali all'estero) 50 anni di esperienza nella costruzione di escavatori ragno (oltre 4000 in tutto il mondo) destinati non solamente alle aree montane, ma anche a quelle paludose e ai canali. L'azienda è certificata ISO 9001 e collabora con i principali produttori mondiali di componenti tecnologici per il miglioramento costante e la ricerca continua di nuove soluzioni per accrescere l'efficienza e la sicurezza delle macchine, alla base del successo dell'azienda. Gli escavatori "ragno" Euromach si distinguono per la loro capacità di lavorare in terreni molto ripidi e difficili, dove l'accesso ai normali mezzi è proibito.

Set up in 1977, Euromach S.r.l grants to their customer (50% of which in foreign countries) 50 years of experience in the construction of walking excavators (more than 4000 all around the world), that are destined to work not only in mountain areas, but also in swamps and channels. The company obtained also the certification ISO 9001 and cooperates with the main world producers of technological components for constant improvement and machines' security, which are the reasons behind the company success. Euromach excavators are ideally suited to work on very steep or rough-terrain sites, where access is severely restricted.

Crée en 1977, Euromach Srl garantie aux clients (dont 50% à l'étranger) 50 années d'expérience dans la construction des pelles araignées (plus de 4000 dans le monde entier) aux terrains de montagne, mais aussi terrains marécageux et aux cours d'eau. L'entreprise est certifiée ISO 9001 et collabore avec les principaux producteurs mondiales de composants technologiques pour une amélioration constante et une recherche continue des nouvelles solutions dans le but d'augmenter l'efficacité et la sécurité des machines, qui sont à la base du succès de l'entreprise. Les pelles araignées Euromach se distinguent pour leur capacité à travailler dans des terrains très raides et difficiles, où l'accès aux moyens traditionnels est interdit.

Die Firma Euromach Srl, wurde im Jahr 1977 gegründet und bringt somit ihren Kunden, welche sich zu 50% im Ausland (mehr als 4000 in der Welt) befindet, eine Erfahrung von über 50 Jahren in der Herstellung von Schreitbaggern entgegen und bürgt daher für technologisch innovative Produkte. Diese Schreitbagger sind für Einsätze konstruiert, welche für andere Maschinen nicht oder nur schwer durchführbar sind. Diese Einsätze beschränken sich nicht nur auf Bergland, Euromach Schreitbagger eignen sich auch besonders gut für Einsätze in sumpfigen Gebieten und Kanälen. Die ISO 9001 Zertifikat gewährleistet die Verwendung von technologischen Komponenten marktführender namhafter Hersteller und eine stetige Forschung und Weiterentwicklung um die Leistung, Standhaftigkeit und Sicherheit der Maschinen zu erhöhen, was nicht zuletzt den Erfolg der Firma begründet.



TIGROTTO



1300 SUPER JOLLY



3500 MOBILE



5500 MOBILE



6500 MOBILE



8500 MOBILE

## R955 super



Il nuovo escavatore Euromach R955 monta un motore Deutz da 142 HP omologato Stage V con filtro antiparticolato incluso; una nuova cabina con migliore visibilità, ergonomia, design e nuovi cofani che ne migliorano l'estetica. L'impianto idraulico per la traslazione ha una pompa idrostatica Rexroth e il distributore del braccio è di tipo Load Sensing. L'impianto idraulico è composto da n. 4 pompe.

The new excavator Euromach R955 mount a 142 HP Deutz engine homologated Stage V with the particulate filter included; a new cab with better visibility, ergonomic, design and new bonnets that improve the aesthetic of the machine. The hydraulic system for the motion has a Rexroth hydrostatic pump and the controlling valve of the boom is in Load Sensing. The hydraulic system is composed by n. 4 pumps.

La nouvelle pelle Euromach R955 monte un moteur Deutz de 142HP homologué Stage V avec le filtre à particules inclus; une nouvelle cabine avec meilleure visibilité, ergonomie et design et nouveaux capots qui en améliorent l'esthétique. Le système hydraulique pour la translation a une pompe hydrostatique Rexroth et le distributeur du bras est de type Load Sensing. Le système hydraulique est composé par n. 4 pompes.

Beim neuen Schreitbagger Euromach R955 wird der neue Motortyp Deutz mit 142HP, integrierter Partikel-filter und homologierter Stage V montiert; eine neue Kabine mit verbesserter Sicherheit, Ergonomie und Design und neuer Motorhaube für eine bessere Ästhetik. Die Antriebshydraulikanlage hat eine Rexroth hydrostatische Pumpe und der Verteiler des Armes ist vom Typ Load Sensing. Die gesamte Hydraulikanlage hat 4 Pumpen.

## Escavatori Euromach / Euromach excavators Pelles Euromach / Bagger Euromach

1500 MOBILE



2500 MOBILE



R455



R 555



R 755



R855 BIGFOOT



R955



R1055



R1255



R145







# EUROMAGH













# Braccio / Boom / Bras / Arm



3 diverse configurazioni braccio: sbraccio massimo da 7750 mm (A) a 8170 mm (C).

3 different configurations of the boom: maximum boom length from 7750 mm (A) to 8170 mm (C).

3 configurations différentes du bras: longueur maximum du bras de 7750 mm (A) à 8170 mm (C).

3 verschiedene Anfertigungen des Armes: Höchststreckweite von 7750 mm (A) bis 8170 mm (C).



N. 5 tubi di serie in punta al braccio. In opzione personalizzabile fino a n. 13 tubi.

N. 5 standard tubes at the end of the boom. In option customizable until to n. 13 tubes.

Num. 5 tuyaux de série à la fin du bras. En option personnalisable jusqu'à n. 13 tuyaux.

Nr. 5 serienmäßige Ölleitungen am Ende des Armes. Optional anpassbar bis zu n. 13 Ölleitungen.



Valvole di sicurezza su bracci.

Security valves on the booms.

Clapets de sécurité sur les bras.

Ventilenkit über die Zylindern.



Tutti i tubi a sinistra in posizione visibile.

All the pipes on the left in visible position.

Touts les tuyaux à la gauche en position visible.

Alle Leitungen an der linken Seite in einer gut sichtbaren Position.



Bielle e puntone derivati da un ragno di 14 ton.

Balance rod and strut rod derived from a spider of 14 ton.

Biellettes et puntone dérivés d'une araignée de 14 ton.

Pleuel und Löffelstange von 14 ton Schreitbagger übernommen.



# Telaio / Chassis / Châssis / Chassis



**option**



**option**





# Zampe / Legs /





# Pattes / Bügeln



**Ruote anteriori con fusello maggiorato.**  
**Front wheels with increased spindle.**  
**Roues avant avec moyeau majoré.**  
**Vorer Raden mit verstärkten**



**Riduttori maggiorati con motore a cilindrata variabile.**  
**Increased gearmotors with variable displacement engines.**  
**Réducteurs à puissance supérieure avec moteurs à débit variable.**  
**Potenzierte Hydromotoren mit variabler Leistung.**



**Blocco del differenziale.**  
**Lockig sytem device.**  
**Blocage du différentiel.**  
**Sperrdifferential.**



**Sfili zampe indipendenti.**  
**Independent telescopic legs.**  
**Extensions des pattes indépendantes.**  
**Unabhängige Teleskopbeine.**



**Staffe sterzanti.**  
**Steering legs.**  
**Pattes avec direction.**  
**Lenkräder.**



# Cabina / Cab /





# Cabine / Kabine

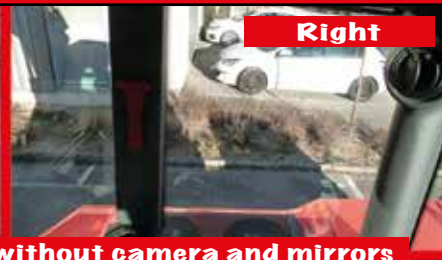



# Nuovi accessori / New accessories / N

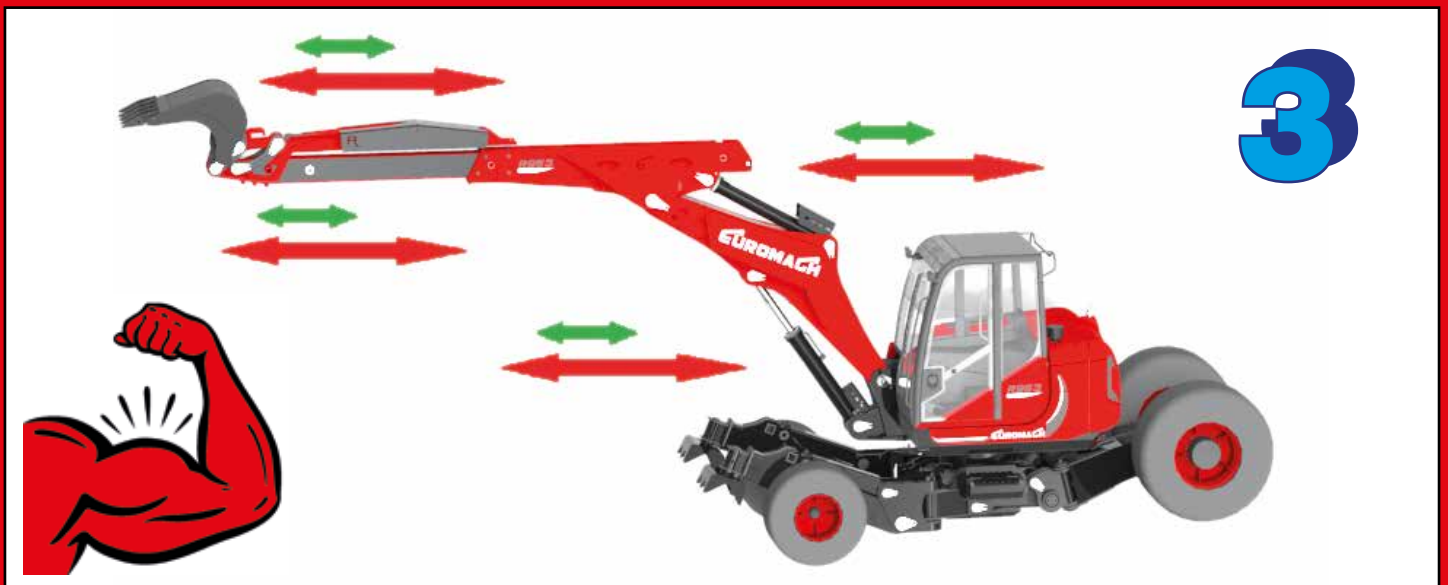
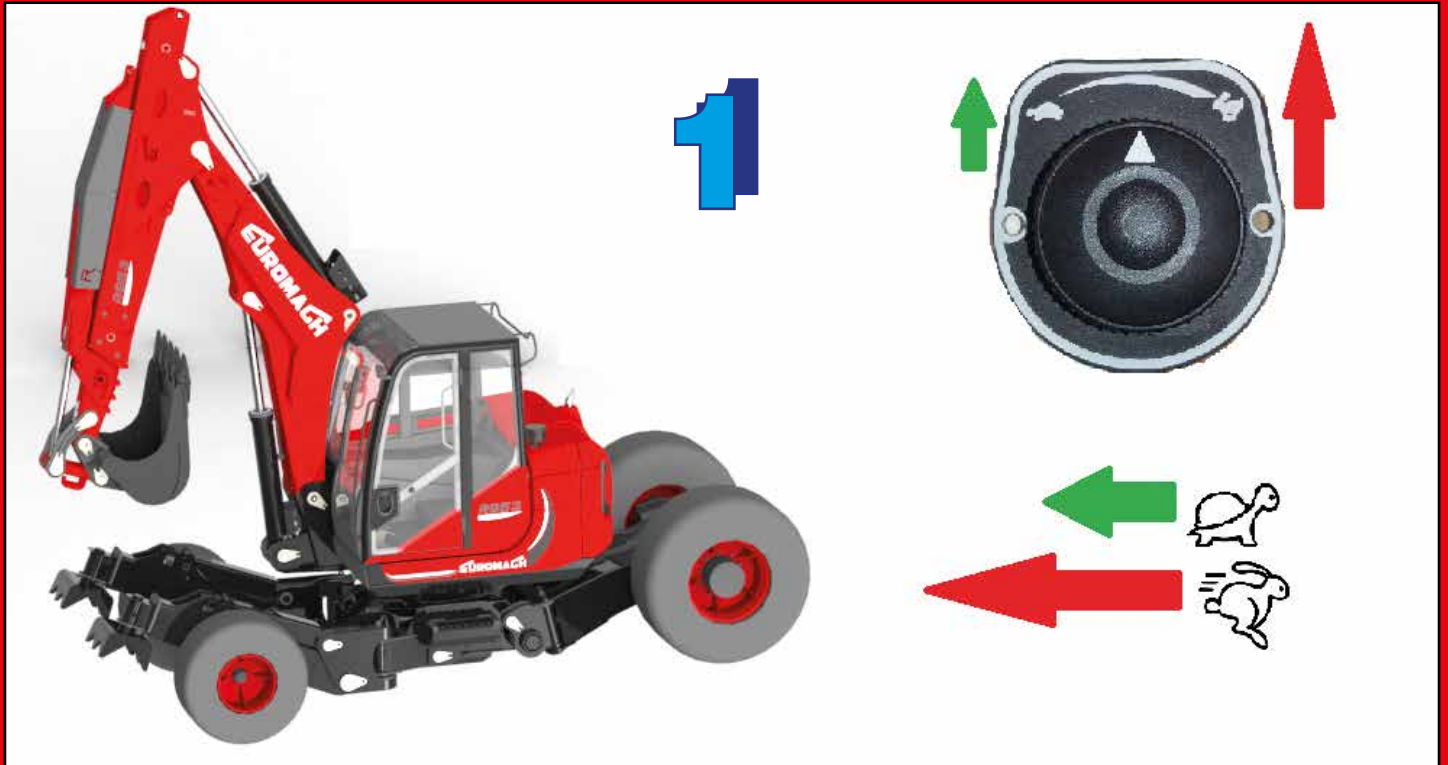



# Nouveaux accessoires / Neue Zubehöre

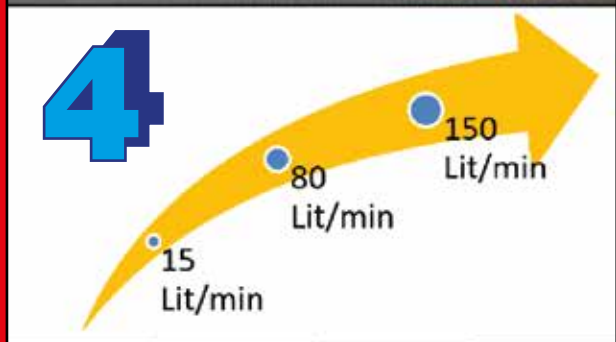
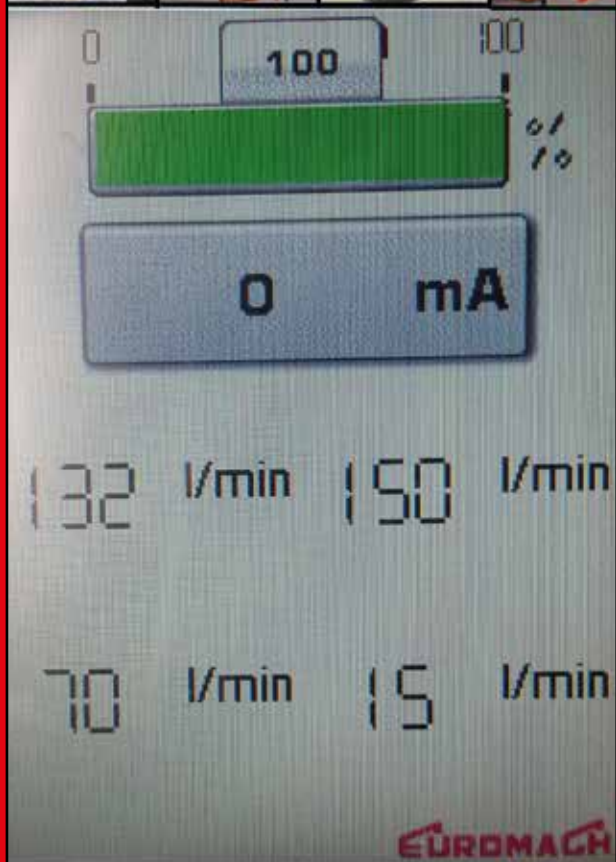

5

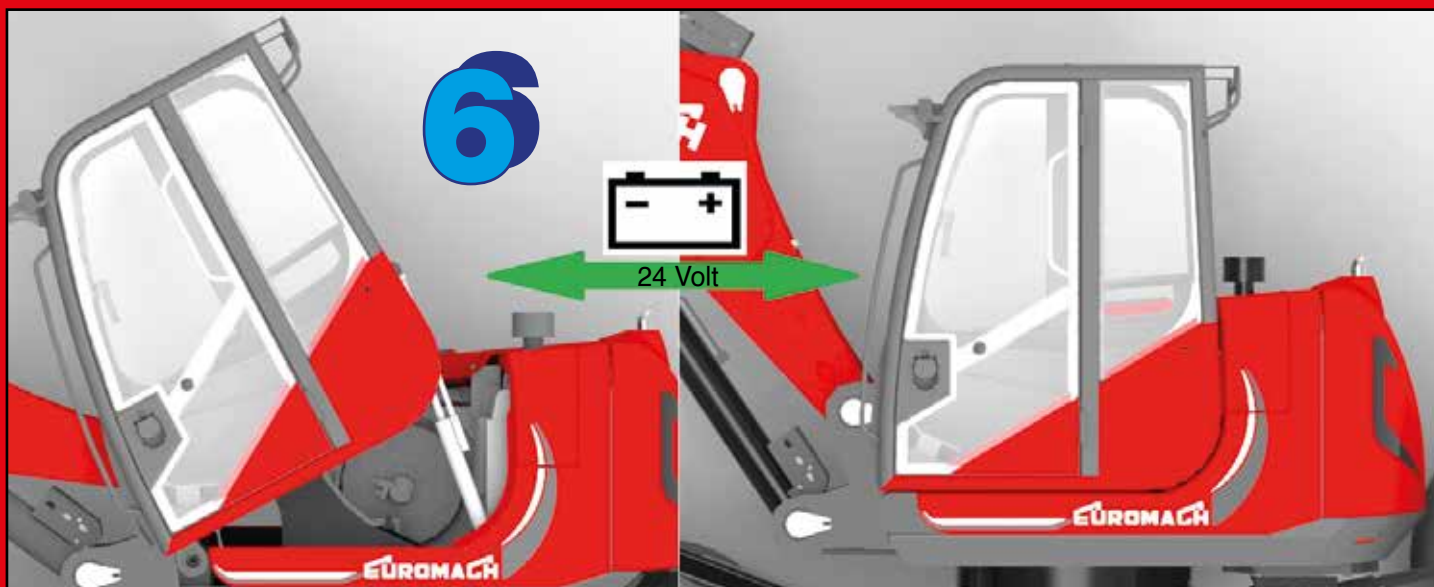



# Optionals

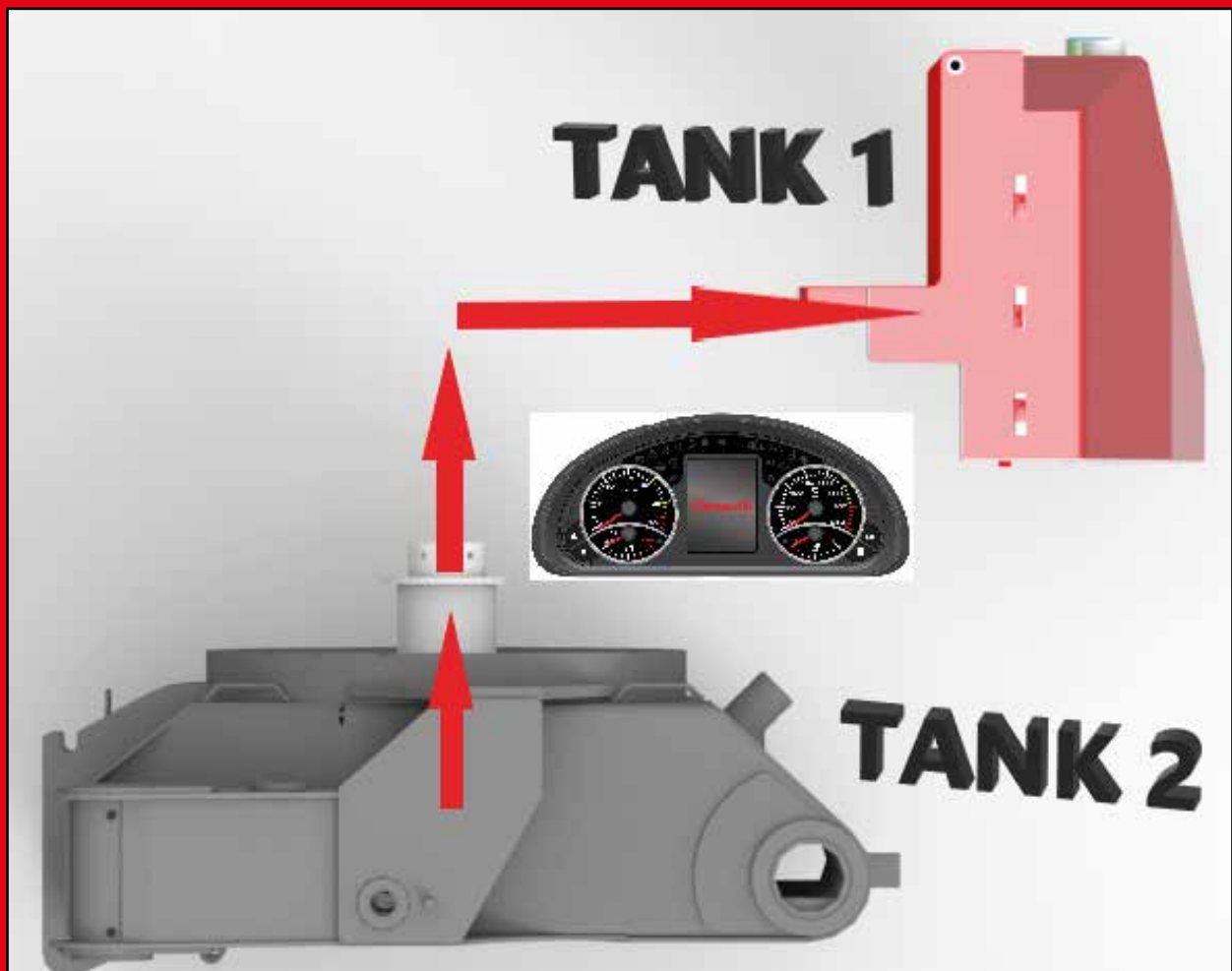



Lexan









# R955 super Motore / Engine / Moteur / Motor

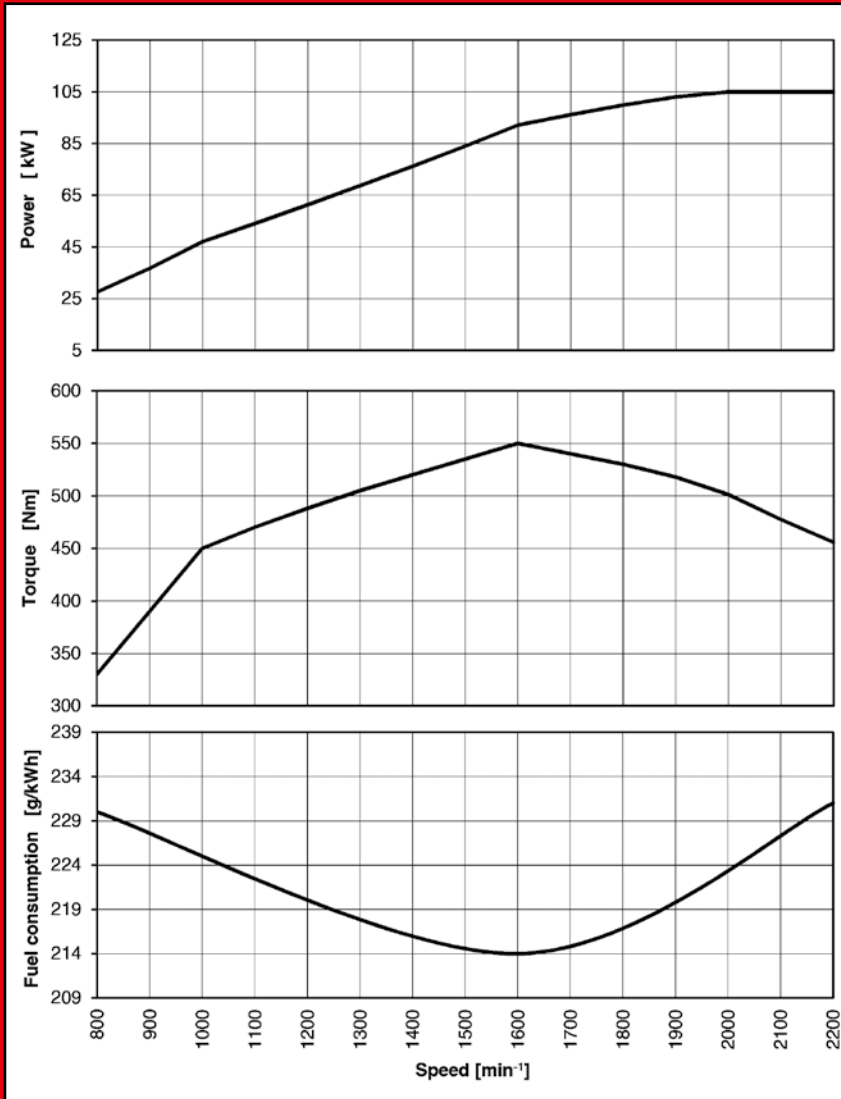

**Modello:** Deutz TCD 3.6 L4 Stage V con filtro antiparticolato e urea  
**Tipo:** Diesel Turbo 4 tempi raffreddato ad acqua, Intercooler  
**Numero cilindri:** 4  
**Cilindrata:** 3600 cm<sup>3</sup>  
**Potenza massima:** 142 Hp (105 kW)  
**Tensione alimentazione:** 24 V  
**Alternatore:** 100 A/h

**Model:** Deutz TCD 3.6 L4 Stage V with particulate filter and urea  
**Type:** 4 strokes water-cooled turbo Diesel, Intercooler  
**Cylinders number:** 4  
**Displacement:** 3600 cm<sup>3</sup>  
**Max power:** 142 Hp (105 kW)  
**Electric system:** 24 V  
**Generator:** 100 A/h

**Modèle:** Deutz TCD 3.6 L4 Stage V avec filtre à particules et urea  
**Type:** Turbo Diesel 4 temps refroidissement par liquide, Intercooler  
**Nombre des cylindres:** 4  
**Cylindrée:** 3600 cm<sup>3</sup>  
**Puissance maximum:** 142 Hp (105 kW)  
**Tension du moteur:** 24 V  
**Générateur:** 100 A/h

**Modell:** Deutz TCD 3.6 L4 Stage V mit Partikelfilter und urea  
**Typ:** Viertakt- Turbodieselmotor mit Flüssigkeitskühlung, Intercooler  
**Zylinderanzahl:** 4  
**Hubraum:** 3600 cm<sup>3</sup>  
**Höchstleistung:** 142 Hp (105 kW)  
**Speisespannung:** 24 V  
**Wechselstromgenerator:** 100 A/h

## STAGE V

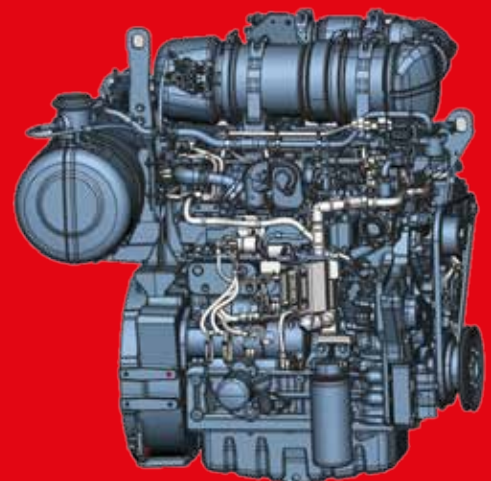



# Nuove sensibilità e affidabilità New sensibility and reliability

**Valvola Rexroth di nuova concezione sul cilindro di sollevamento (più sensibile).**

**Nuova valvola Rexroth rigenerativa sul cilindro del secondo braccio.**

**Rexroth valve of new concept on the lifting boom (more sensibility).**

**New regenerative Rexroth valve on the second boom cylinder.**



**Valve Rexroth de nouvelle conception sur le vérin du levage (plus sensible).**

**Nouvelle valve régénératrice Rexroth sur le vérin du deuxième bras.**

**Rexroth Ventil von neuer Konzeption auf dem Hubzylinder (mehr Sensibilität).**

**Neues regeneratives Rexroth Ventil auf dem Zylinder des zweites Armes.**

**Rex**  
Bosch

**Riduttore di rotazione Poclain; motore idraulico diretto senza ingranaggi: più sensibilità e forza.**

**Poclain's reduction gear; hydraulic motor without gearwheel: more sensibility and force.**



**Rèducteur de rotation Poclain. Moteur hydraulique direct sans engrenages. Plus de sensibilité et plus de force.**

**Untersetzungsgetriebe von Poclain; Wasserkraftmaschine ohne Getrieben: mehr Empfindlichkeit und Kraft.**

**POCLAIN**  
Hydraulics



# Nouvelle sensibilité et fiabilité Neue Sensibilität und Zuverlässigkeit



Una nuova valvola Rexroth sul traino funge da blocco del differenziale. Le 2 ruote si muoveranno in modo sincrono anche con differenti pressioni al suolo delle stesse.

A new Rexroth valve on the traction makes the differential locking device function. The 2 wheels will move synchronously even if they have different pressures to the ground.

Une nouvelle valve Rexroth sur la traction fait le blocage du différentiel. Les 2 roues se déplacent en manière synchrone même s'elles ont des pressions différentes sur le sol.

Ein neues Ventil Rexroth auf den Antrieb macht die Funktion als Sperrdifferential. Beide Räder werden in einer synchronen Weise, sogar mit unterschiedlichen Drücken auf den Boden bewegt.

**roth**®  
Group



Abbiamo sviluppato con Hydreco dei nuovi corpi manipolatori. Lo sforzo per comandare la leva è molto basso e la sensibilità sul movimento del cilindro molto maggiore.

In cooperation with Hydreco we have developed new bodies for the manipulators. The effort to control the lever is very low and the sensitivity on the cylinder movement is higher.

Nous avons développé avec Hydreco de nouveaux corps de manipulateurs. L'effort pour contrôler le levier est très bas et la sensibilité sur le mouvement du vérin est supérieure.

Wir haben mit Hydreco neue Körper für die Manipulatoren entwickelt. Der Aufwand um den Hebel zu kontrollieren ist sehr niedrig und die Sensibilität der Zylinderbewegung ist viel größer.

**HYDRECO**®  
HYDRAULIC SOLUTIONS PROVIDER



# Impianto principale - Braccio

## Main system - Boom

### Système principal - Bras

#### Hauptanlage - Arm



**POCLAIN**<sup>®</sup>  
Hydraulics



**Rexroth**<sup>®</sup>  
Bosch Group



**N. 4 pompe**

**N. 2 distributori separati**

**Totale olio: 175 + 175 + 130 + 35 = 515 l/min**

**Pressione di lavoro: 300 bar**

**N. 4 pumps**

**N. 2 separated control valves.**

**Total oil: 175 + 175 + 130 + 35 = 515 l/min**

**Working pressure: 300 bar**

**N. 4 pompes**

**N. 2 distributeurs séparés**

**Totale huile: 175 + 175 + 130 + 35 = 515 l/min**

**Pression de travail: 300 bar**

**N. 4 Pumpen**

**N. 2 getrennte Verteiler**

**Gesamtöl: 175 + 175 + 130 + 35 = 515 l/min**

**Arbeitsdruck: 300 bar**



# Impianto di traslazione / Translation system Système de translation / Fahrtrieb

Impianto di traslazione mediante pompa idrostatica e motori Rexroth a cilindrata variabile.  
Pressione di lavoro 450 bar  
Portata massima 130 L/min  
Velocità massima 8 Km/h (option 12 km/h).  
Grande potenza.

Translation system with hydrostatic Rexroth pump and variable displacement engines.  
Working pressure 450 bar  
Max. displacement 130 L/min  
Max. speed 8 Km/h (option 12 km/h).

Système de translation avec pompe hydrostatique et moteurs Rexroth à débit variable.  
Pression de travail 450 bar  
Débit maximum 130 L/min  
Vitesse maximum 8 Km/h (option 12 km/h).  
Grande puissance.

Fahrtriebspumpe vom Typ „Rexroth“ hydrostatisch und Motor mit variabler Leistung.  
Arbeitsdruck 450 bar  
Max. Leistung 130 L/min  
Höchstgeschwindigkeit 8 Km/h (Option 12 km/h).  
Große Macht.

**Rexroth**<sup>®</sup>  
Bosch Group



## OPTION: Double towing pump

N. 5 pompe  
N. 2 distributori separati  
Totale olio: 175 + 175 + 90 + 90 + 35 = 565 l/min  
Pressione di lavoro: 450 bar

N. 5 pompes  
N. 2 distributeurs séparés  
Totale huile: 175 + 175 + 90 + 90 + 35 = 565 l/min  
Pression de travail: 450 bar

N. 5 pumps  
N. 2 separated control valves  
Total oil: 175 + 175 + 90 + 90 + 35 = 565 l/min  
Working pressure: 450 bar

N. 5 Pumpen  
N. 2 getrennte Verteiler  
Gesamtöl: 175 + 175 + 90 + 90 + 35 = 565 l/min  
Arbeitsdruck: 450 bar

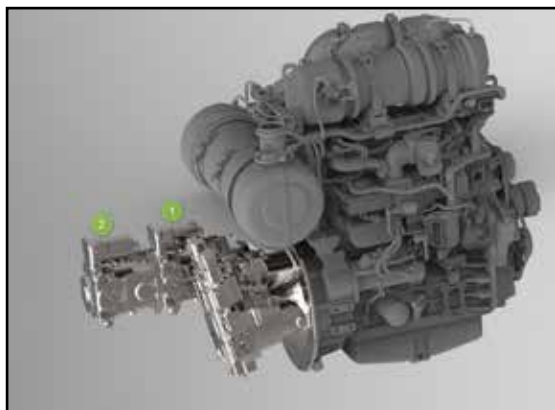

## OPTION: Priority Line



Linea prioritaria per accessorio idraulico con portata e pressione indipendenti dal movimento dell'escavatore.

Priority line for the hydraulic accessory with independent displacement and pressure from the excavator movement.

Ligne prioritaire pour accessoire hydraulique avec débit et pression indépendants du mouvement de la pelle.

Vorrangige Linie für Hydraulikzubehör mit Leistung und Druck unabhängig von der Bewegung des Baggers.



# R955 super

## DATI PRINCIPALI

- ⇒ N° 2 serbatoi del gasolio = 300 lit (principale 130 lit, secondario nel telaio 170 lit). L'escavatore è munito di una pompa per il trasferimento del carburante dal serbatoio secondario a quello principale (travasamento elettrico optional).
- ⇒ Cabina antiribaltamento, nuovo disegno, con vetro apribile verso l'interno, ROPS/FOPS, miglior comfort e più spazio per l'operatore; cristalli temperati, autoradio con CD e sedile ad aria.
- ⇒ I componenti maggiormente sollecitati sono realizzati utilizzando materiali ad alto limite elastico. I cucchiai ed i piedi di appoggio sono con particolari acciai antiusura per aumentarne la resistenza all'uso. I perni sono realizzati in acciaio 16CrNi4 cementato e gli steli dei cilindri sono in 42CrMo4 bonificato e temprato ad induzione e successivamente cromato per avere massima robustezza e resistenza all'usura.

## MAIN DATA

- ⇒ N° 2 diesel tanks = 300 lit (main tank 130 lit, secondary tank 170 lit). The excavator is equipped with a pump that can be used to transfer the Diesel from the secondary tank to the main tank (optional electric pouring).
- ⇒ Anti-roll cabin, new design, front window opens towards the cabin, ROPS/FOPS, more comfort, more space for the operator, tempered and colored glass windows, car radio set with CDs, air seat.
- ⇒ The most stressed parts of the excavator are made out of high strength steel. Buckets and legs are made out of special steel that has a high resistance against wearing. The pins are made out of case-hardened 16CrNi4 steel and the cylinders piston rods are made out off induction hardened and tempered 42CrMo4 steel successively chromed to warrant a good strength and a surface resistance against chocks.

## DONNES PRINCIPALES

- ⇒ N° 2 réservoirs à gasoil = 300 lit (principale 130 lit, réserve 170 lit). La pelle est équipée d'une pompe qui peut être utilisé pour le transfert du carburant du réservoir secondaire à ce principal (transfert automatique du gasoil en option).
- ⇒ Cabine anti-renversement, nouvel design, vitre antérieure avec ouverture à l'intérieur, ROPS/FOPS, plus de confort, plus d'espace pour l'opérateur, glaces trempées et colorées, autoradio avec CD, siège à air.
- ⇒ Les parties de l'excavateur les plus fatiguées, sont réalisées avec de matériels qui ont une limite d'élasticité très élevée. Les bennes et les pieds d'appui sont réalisés en acier spécial avec une résistance élevée à l'usure. Les pivots sont réalisés en acier 16CrNi4 cimenté et les tiges des cylindres sont réalisés en acier 42CrMo4 bonifié et trempé à induction et successivement chromé afin de garantir une considérable robustesse et une résistance de la surfaces aux chocs très élevés.

## HAUPTDATEN

- ⇒ N° 2 Treibstofftanks = 300 Lit. (Haupttank 130 Lit, Ersatztank 170 Lit). Eine spezifische Tankpumpe wird geliefert, um den Treibstoff vom Ersatztank in den Haupttank zu pumpen (elektrisches Umfüllen in Option).
- ⇒ Kippsichere Kabine, neues Design, Vorderscheibe mit Öffnung nach Innen, ROPS/FOPS, besseren Komfort, mehr Platzangebot für der Maschinenführer, gehärtete Scheiben, Autoradio mit CD, LuftsitzKab.
- ⇒ Die Komponente des Baggers, welche e Höchstbeanspruchung haben, werden aus hohem elastischem Qualitätsmaterial hergestellt. Die Löffeln und die Auf lagefüße werden aus besonderen Antiverschleißstählen gemacht, um d i e Gebrauchsfestigkeit zu erhöhen. Die Bolzen werden aus Stahl 16CrNi4 hergestellt und die Kolbenstangen werden aus vergütetem, induktionsgehärtetem und danach verchromten 42CrMo4 Stahl hergestellt; das verbürgt für eine bemerkenswerte Stärke und eine hohe oberflächliche Schlagfestigkeit.

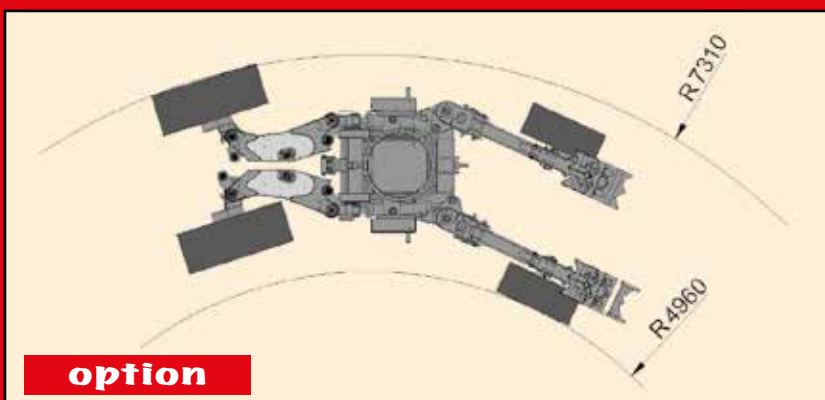
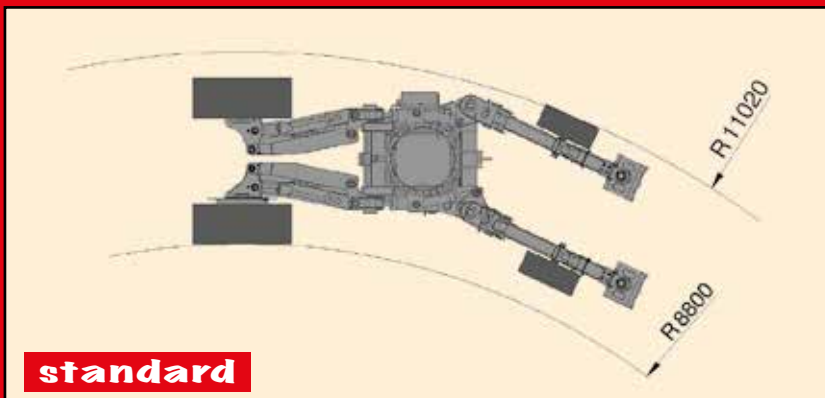

## 4wd wheels tilting

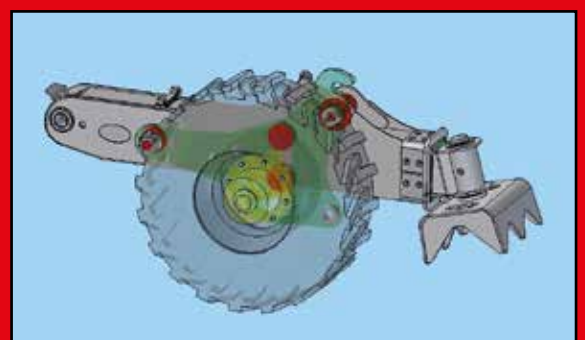
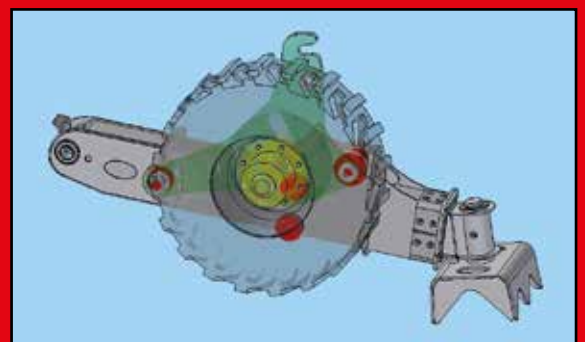



# Standard version

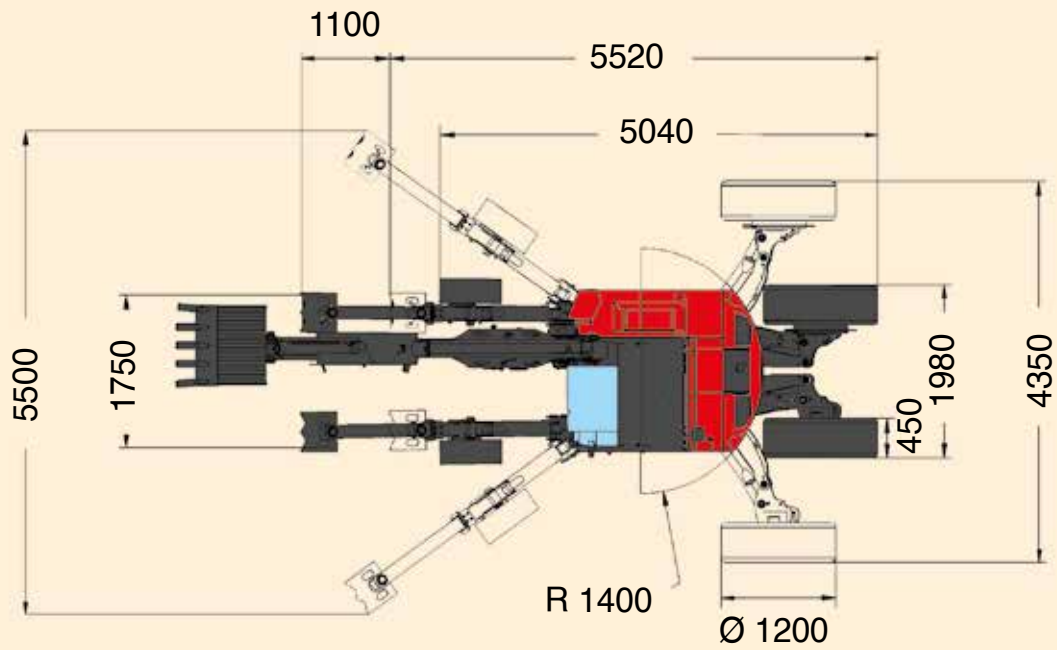

# Steering legs (option)

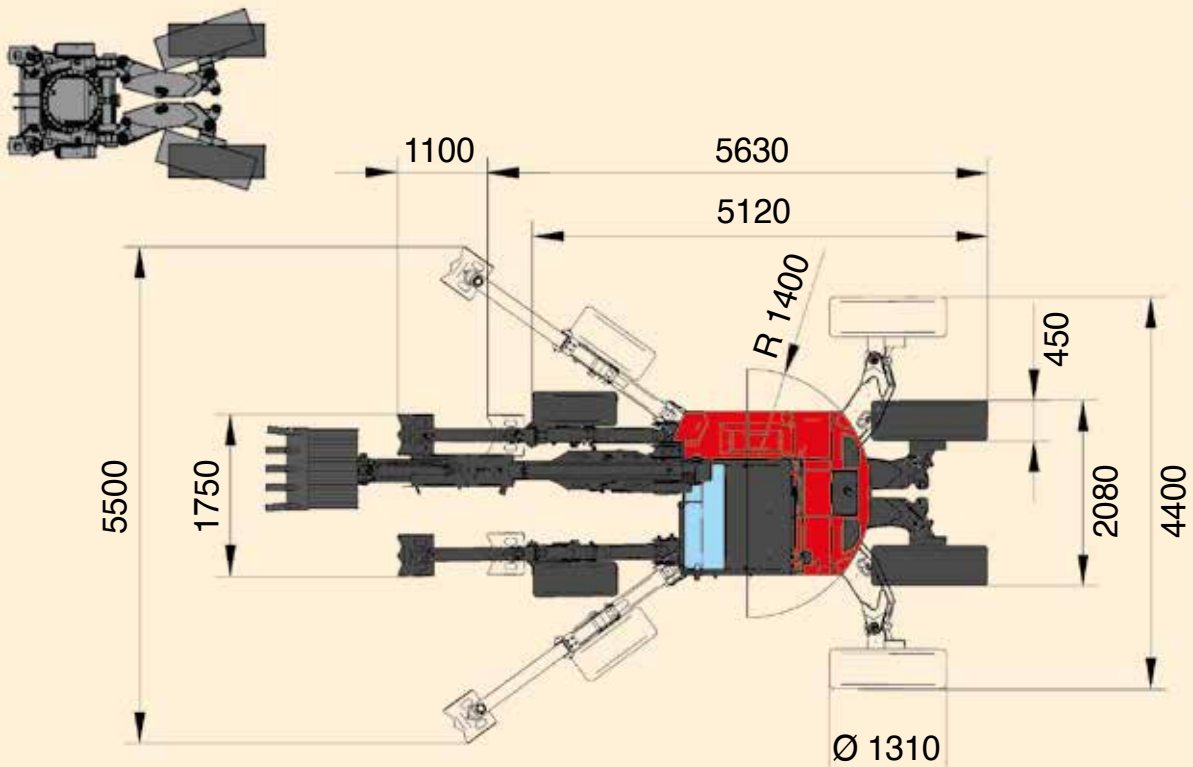



# R955 super - Version A

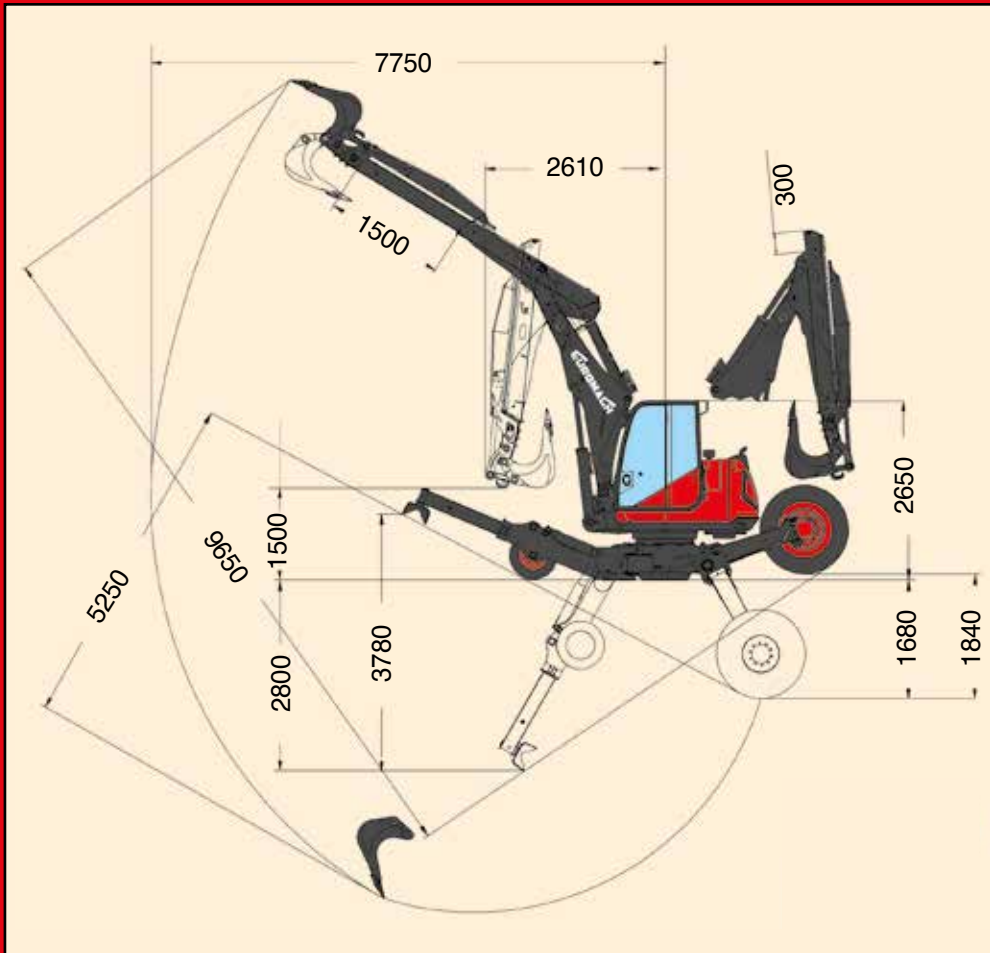

**Peso 2wd: da 10000 kg**  
**Peso 4wd: da 10500 kg**  
**Sfilo braccio: 1,5 m**  
**Sbraccio massimo: 7,75 m**  
**Forza di strappo: 110 kn**  
**Forza di penetrazione: 62 kn**

**Weight 2wd: from 10000 kg**  
**Weight 4wd: from 10500 kg**  
**Boom extension: 1,5 m**  
**Max. boom length: 7,75 m**  
**Brake off force: 110 kn**  
**Penetration force: 62 kn**

**Poids 2wd: de 10000 kg**  
**Poids 4wd: de 10500 kg**  
**Extension du bras: 1,5 m**  
**Longueur max. bras: 7,75 m**  
**Force d'enlèvement: 110 kn**  
**Force de pénétration: 62 kn**

**Gewicht 2wd: von 10000 kg**  
**Gewicht 4wd: von 10500 kg**  
**Teleskop Ausleger: 1,5 m**  
**Höchstrechtweite: 7,75 m**  
**Reißkraft: 110 kn**  
**Durchschlagskraft: 62 kn**

# R955 super - Version B

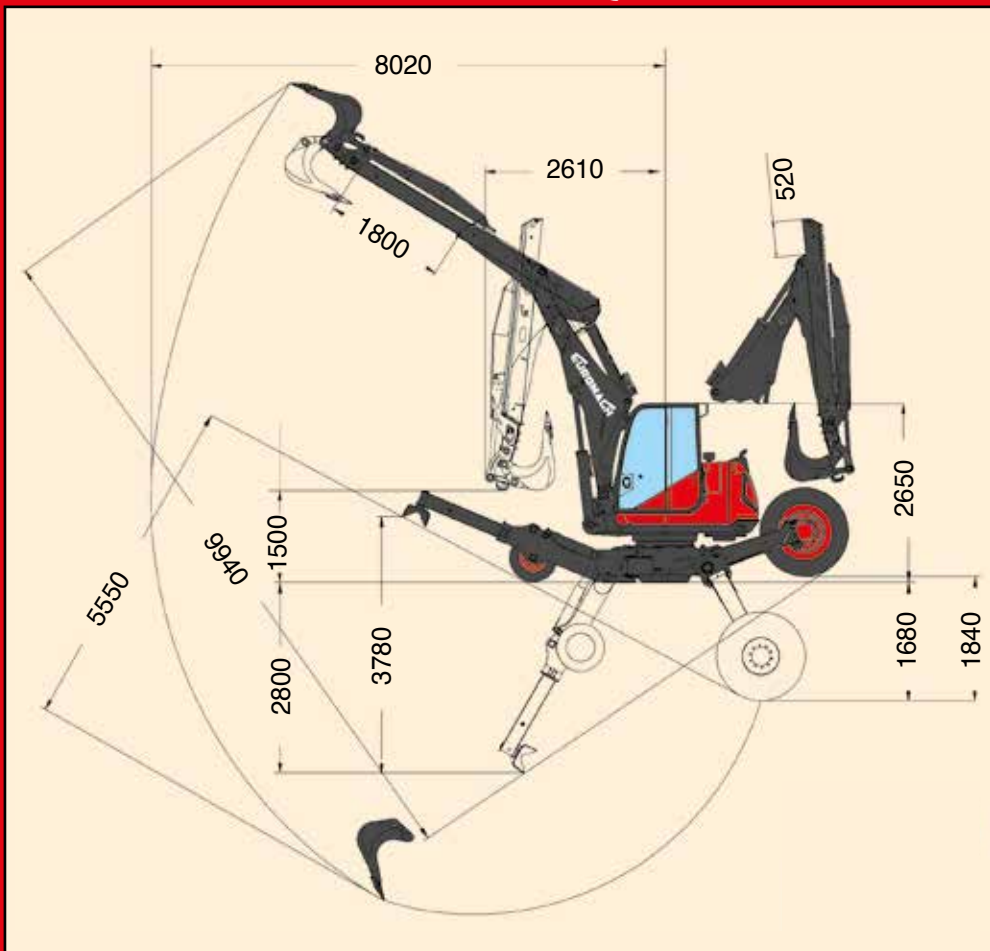

**Peso 2wd: da 10100 kg**  
**Peso 4wd: da 10600 kg**  
**Sfilo braccio: 1,8 m**  
**Sbraccio massimo: 8,02 m**  
**Forza di strappo: 110 kn**  
**Forza di penetrazione: 62 kn**

**Weight 2wd: from 10100 kg**  
**Weight 4wd: from 10600 kg**  
**Boom extension: 1,8 m**  
**Max. boom length: 8,02 m**  
**Brake off force: 110 kn**  
**Penetration force: 62 kn**

**Poids 2wd: de 10100 kg**  
**Poids 4wd: de 10600 kg**  
**Extension du bras: 1,8 m**  
**Longueur max. bras: 8,02 m**  
**Force d'enlèvement: 110 kn**  
**Force de pénétration: 62 kn**

**Gewicht 2wd: von 10100 kg**  
**Gewicht 4wd: von 10600 kg**  
**Teleskop Ausleger: 1,8 m**  
**Höchstrechtweite: 8,02 m**  
**Reißkraft: 110 kn**  
**Durchschlagskraft: 62 kn**

# R955 super - Version C

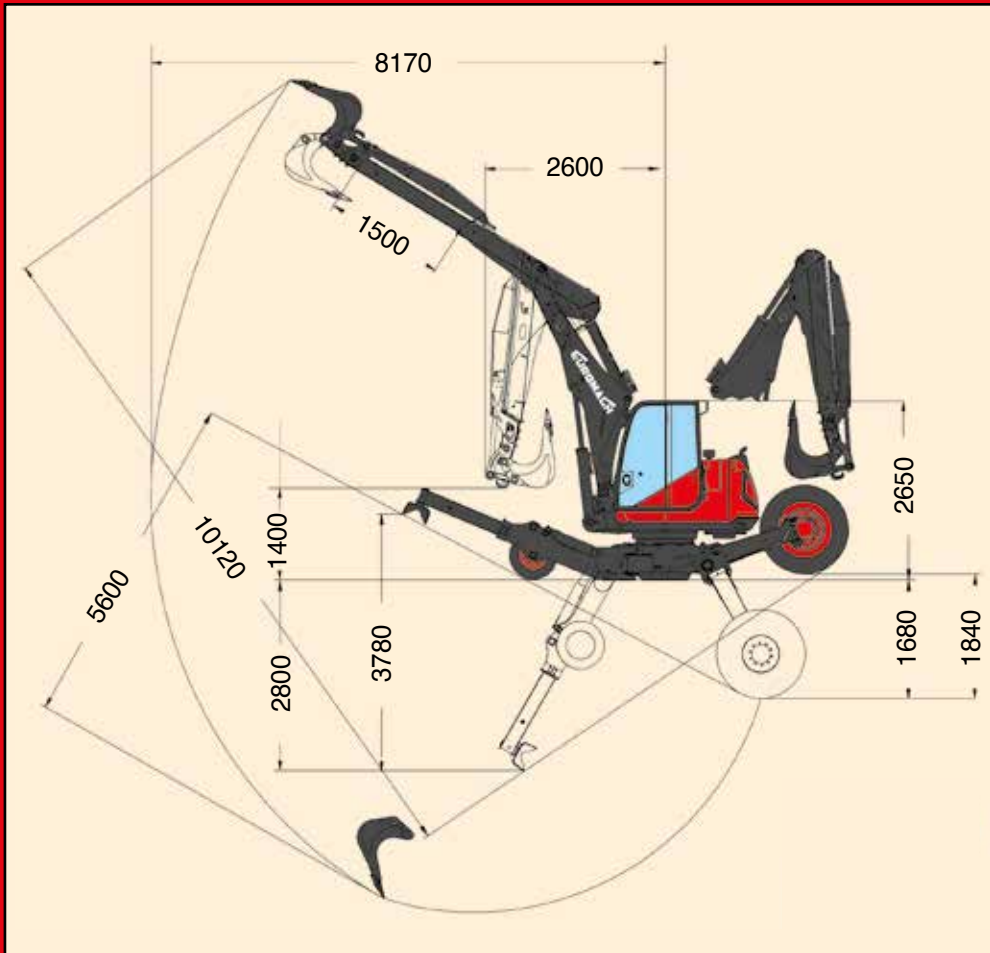

**Peso 2wd: da 10200 kg**  
**Peso 4wd: da 10700 kg**  
**Sfilo braccio: 1,5 m**  
**Sbraccio massimo: 8,17 m**  
**Forza di strappo: 110 kn**  
**Forza di penetrazione: 65 kn**

**Weight 2wd: from 10200 kg**  
**Weight 4wd: from 10700 kg**  
**Boom extension: 1,5 m**  
**Max. boom length: 8,17 m**  
**Brake off force: 110 kn**  
**Penetration force: 65 kn**

**Poids 2wd: de 10200 kg**  
**Poids 4wd: de 10700 kg**  
**Extension du bras: 1,5 m**  
**Longueur max. bras: 8,17 m**  
**Force d'enlèvement: 110 kn**  
**Force de pénétration: 65 kn**

**Gewicht 2wd: von 10200 kg**  
**Gewicht 4wd: von 10700 kg**  
**Teleskop Ausleger: 1,5 m**  
**Höchststreckweite: 8,17 m**  
**Reißkraft: 110 kn**  
**Durchschlagskraft: 65 kn**





# Accessori / Accessories

## CUCCHIAI / BUCKETS / BENNES / LÖFFELN



## ARGANI / WINCHES / TREUILS / WINDEN



## PINZE / GRABS / BENNES PRENEUSES / GREIFERN





# / Accessoires / Zubehöre

## FRESE E PROCESSORI / MULCHERS AND PROCESSORS BROYEURS ET PROCESSEURS / MULCHERN UND PROZESSOREN



## ROTATORI E ATTACCHI RAPIDI / ROTATORS AND QUICK COUPLERS ROTATEURS ET ATTACHES RAPIDES / ROTATOREN UND SCHNELLWECHSLERN



## ALTRI ACCESSORI / OTHER ATTACHMENTS AUTRES EQUIPEMENTS / ANDERE ZUBEHÖRE







## R955 super

EUROMACH S.R.L.  
25018 MONTICHIARI (Brescia)  
ITALY  
Via Gabriele D'Annunzio, 28/30  
Phone 0039(0)-30-9960527  
Fax 0039(0)-30-9960363  
www.euromach.com  
e-mail: euromach@euromach.com



- A fronte di una continua ricerca tecnologica, i dati possono cambiare senza preavviso. Contattare il nostro Ufficio Commerciale per ulteriori informazioni.  
- Because of continuous technology research data can change without notice. Please, contact our Commercial Dept. for further information.  
- Vu la recherche technologique continue, les données peuvent changer sans préavis. Contacter notre Bureau Commercial pour des autres informations.  
- Wegen technischer Forschung, können die Daten fristlos ändern. Unser Vertrieb erteilt Ihnen gerne weitere Auskünfte, bitte rufen Sie an.